

micro2R

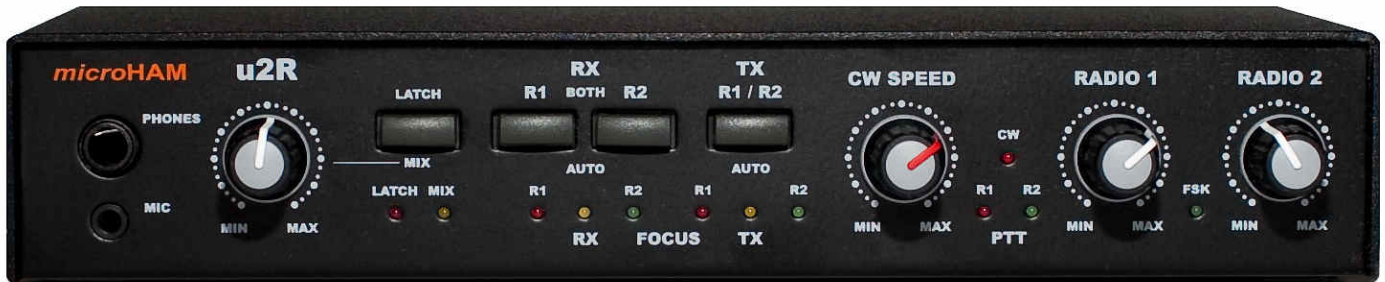

u2R

microHAM

fax: +421 2 4594 5100
e-mail: support@microham.com
homepage: www.microham.com

Version 8.0
1 March, 2016

TABLE OF CONTENTS

CHAPTER	PAGE
1. FEATURES AND FUNCTIONS	4
2. IMPORTANT WARNINGS	5
3. PANEL DESCRIPTION	6
Front Panel	6
Rear Panel	8
4. INSTALLATION	10
Preparing micro2R for Use.....	10
Installing <i>microHAM</i> USB Device Router	12
Configuring <i>microHAM</i> USB Device Router	13
Creating and Using Virtual Serial Ports	14
5. <i>microHAM</i> DEVICE ROUTER	15
Menu: Router	15
Menu: Preset	16
Menu: Device	17
Menu: Virtual Port	18
Menu: Help	19
Device Configuration Tabs	19
Ports Tab	20
Ports: FSK & 2 nd FSK	21
Ports: CW	22
Ports: PTT & 2 nd PTT	23
Ports: WinKeyer2	24
Ports: Control	25
Ports: Foot Switch	25
Ports: CW and PTT from LPT (parallel port).....	26
Ports: CW/PTT Steering	26
Ports: Steer FSK	26
Ports: Steer WinKey CW/PTT	26
Audio Tab	27
PTT & ACC Tab	30
CW/WinKey Tab	32
CW Messages Tab	33
FSK Messages Tab	34
DVK Tab	35
Keyboard Tab	36
SO2R Tab	37
6. <i>micro2R</i> OPERATION	39
Setting Audio Levels	39
Configuring <i>micro2R</i> for your radios	39
Setting Audio Levels	40
Understanding Transmit (TX) Focus	42
Understanding Headphone Switching	43
Understanding Interlocks	44
System Considerations	44
External Keyboard/Numeric Keypad	45
7. HARDWARE SPECIFICATIONS	47
8. PACKAGE CONTENTS	48

9. WARRANTY	48
DECLARATION OF CONFORMITY	49
APPENDIX A – CONNECTORS	50
APPENDIX B – RFI Considerations	52
APPENDIX C – Cables and Bridges	53
APPENDIX D – Typical Hardware Configurations	54

1 - FEATURES AND FUNCTIONS

General:

- USB (advanced mode) or LPT ("classic" mode) control
- *microHAM* Control Protocol supported by major contest software.
- two "Band Data" outputs controlled by logging software
- independent, front panel, transmit level controls for each transceiver
- manual or automatic transceiver selection
- two UART compatible FSK outputs
- foot switch support
- "selected transmitter" outputs for station automation interface
- compatible with most standard Windows based logging or control programs
- DOS mode compatibility with LPT port interface of DOS based contest loggers (CT, TR, NA)

Keying:

- optically isolated USB and LPT inputs.
- hardware support for "last one wins" or "first one wins" operation
- programmable PTT assertion delay in 1ms steps
- supports separate PTT for each radio with automatic TX focus control
- supports VOX and CAT T/R switching

CW:

- integrated second generation K1EL WinKey2™
- front panel speed knob
- nine (9) user programmable memories
- application independent contest auto-numbering
- supports PS/2 keyboard for CW transmission with type ahead
- supports PS/2 keyboard or keypad for CW "memory keyer" and control
- PS/2 keyboard or keypad CW works without computer connection
- multiple CW sources: WinKey2, serial port and/or LPT port with steering

Voice (SSB/AM/FM):

- front panel headset jacks
- selectable electret bias (+8V) on mic (tip or ring)
- wide range preamplifier supports both dynamic and electret microphones.
- Unique microphone switching allows microphone to loop through the sound card for VOX or override the sound card/mute DVK when the footswitch/PTT is activated.
- Transceiver PTT input for correct headphone switching during VOX operation
- Digital Voice Keyer with nine messages up to 120 seconds line and unlimited "banks"

Headphone (Receive) Audio:

- front panel headphones jack
- passive audio processing with selectable transformer isolation or direct coupling
- front panel mix control
- user selectable "delayed" headphone switching (100ms steps)
- manual controls for "classic" audio R1/SPLIT/R2 or R1/MIX/R2 functions
- easy switching between manual and automatic control

Other:

- integrated chokes and filters for maximum RFI immunity
- Metal/Aluminum case, powder coated and silk screened
- Free, no time limit firmware/software upgrades via Internet

2 - IMPORTANT WARNINGS

ALWAYS check the polarity of the 13.8 V power supply.

Remember, under Windows, *microHAM* USB Device Router must be running anytime the interface is used (not just for setup). If Router is not running, the virtual COM ports will disappear and the device cannot be accessed!

3 - PANEL DESCRIPTION

Front Panel

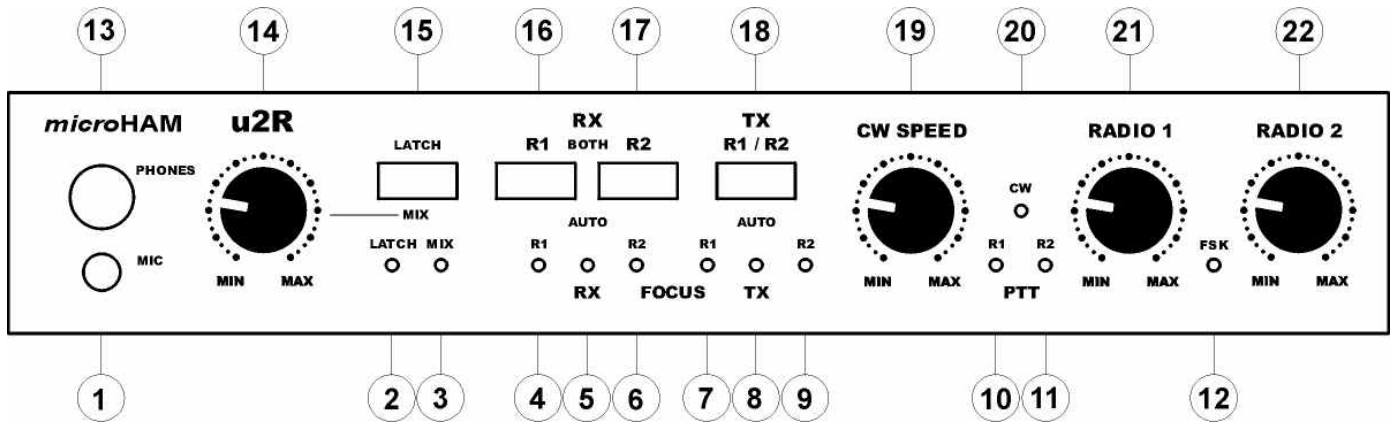

- (1) **MIC:** Microphone input (headset microphone).
Connector: 3.5mm (1/8") stereo
TIP – Signal (bias) RING – NC (bias) SHELL – Shield
- (2) **LATCH:** Indicates when "latch" mode is selected.
Toggle status by a short press of the Latch/Mix button.
- (3) **MIX:** Indicates when audio mixing is selected.
Toggle status by a long press of the Latch/Mix button.
- (4) **RX R1:** Receiver 1 active.
- (5) **RX AUTO:** Receiver selection is controlled by logging program or follows transmitter selection.
- (6) **RX R2:** Receiver 2 active.
- (7) **TX R1:** Transmitter 1 active.
- (8) **TX AUTO:** Transmitter selection is controlled by logging program.
- (9) **TX R2:** Transmitter 2 active.
- (10) **PTT R1:** Indicates Radio 1 PTT is active.
- (11) **PTT R2:** Indicates Radio 2 PTT is active.
- (12) **FSK:** Blinks with FSK output.
- (13) **PHONES:** Output for operator headphones.
Connector: 6.3mm (1/4") stereo
TIP – Left RING – Right SHELL – Common
- (14) **MIX:** Controls the level of mixing between the left and right headphone channels.
- (15) **LATCH:** Tap to toggle "Latch" status, Hold to toggle "Mix."

(16) RX RADIO1: Disables automatic headphone switching if it was enabled (switch to manual mode) and connect headphones to RADIO1.

(17) RX RADIO2: Disables automatic headphone switching if it was enabled (switch to manual mode) and connect headphones to RADIO2.

NOTE: A short press on **BOTH** R1 (16) and R2 (17) will select the left channel (usually main RX) from Radio 1 to the left ear and the left channel (usually the main RX) from Radio 2 to the right ear.

A long press of **BOTH** R1 (16) and R2 (17) at the same time enables automatic headphone switching (AUTO mode). If enabled, the yellow AUTO light will be lit; the R1 (4) and R2 (6) lights indicate receive focus.

(18) TX R1/R2: A short press alternately selects transmission on RADIO1 or RADIO 2 and disables automatic control of transmit focus if it was enabled. A long press enables automatic control of transmit focus (selected transmitter).

(19) CW SPEED: Provides manual control of the WinKeyer2. Minimum and Maximum speeds are defined by software.

(20) CW: Indicates the CW output is active.

(21) RADIO 1: Adjusts drive level to RADIO1.

(22) RADIO 2: Adjusts drive level to RADIO2.

Rear Panel

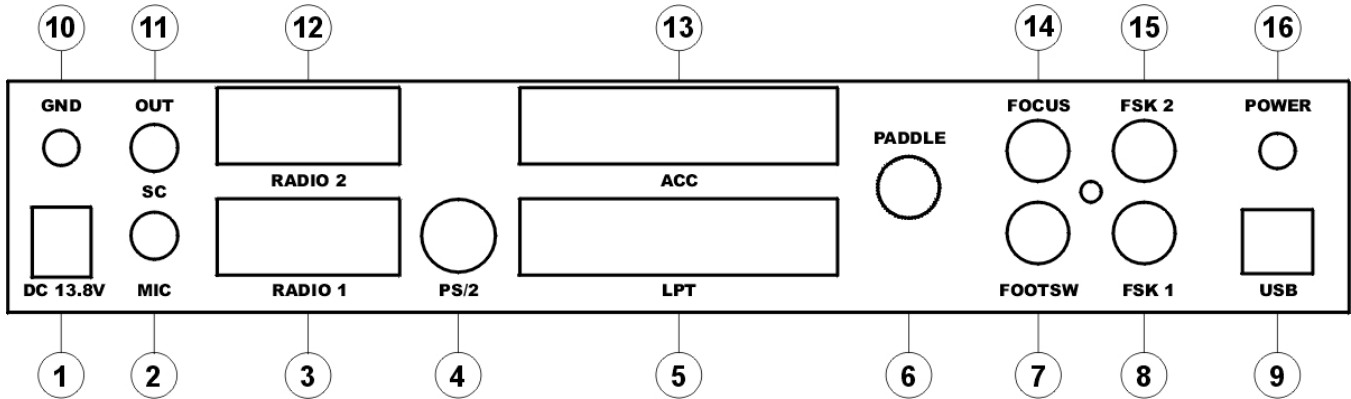

(1) DC 13.8 V: Power input.

Connector: 2.1/5.5mm coaxial
CENTRAL – Positive pole SHELL – Negative pole (Ground)

NOTE: DO NOT connect micro2R to any power supply used for either transceiver.

IMPORTANT WARNING: Be sure to observe the proper polarity!

(2) SC MIC: Connection to sound card microphone input.

Connector: 3.5mm (1/8") stereo
TIP – Signal RING – unused SHELL – Ground

(3) RADIO1: Multi-pin jack for RADIO1 interconnection.

Connector: DB9 female
Detailed description is in Appendix A.

(4) PS/2: Port for connection of external PS/2 keyboard or numeric keypad.

Connector: Mini DIN6

(5) LPT: Input from computer LPT (printer) port.

Connector: DB25 female

(6) PADDLE: Paddle input.

Connector: 6.3mm (1/4") stereo
TIP – DIT Input RING – DAH Input SHELL – Ground

(7) FOOTSW: Footswitch input.

Connector: RCA, active when grounded.
TIP – Signal SHELL – Ground

(8) FSK 1: FSK Output for Radio 1

Connector: RCA, Grounded/closed on MARK
TIP – Signal SHELL – Ground

(9) USB: Port for connection to the computer USB port.

Connector: USB B

(10) GND: Terminal for connection to station common ground.

- (11) SC OUT:** Connection from sound card Line Out.
Connector: 3.5mm (1/8") stereo
TIP – Left (Radio 1) RING – Right (Radio 2) SHELL – Ground
- (12) RADIO2:** Multi-pin jack for RADIO2 interconnection.
Connector: DB9 female
Detailed description is in Appendix A.
- (13) ACC:** external multi-function I/O port (see ACC Port section of this manual).
Connector: DB25 female
Pin description is in Appendix B.
- (14) FOCUS:** Focus status output.
Connector: RCA, grounded when active.
Open collector: +12V/50mA maximum.
TIP – Signal SHELL – Ground
- (15) FSK 2:** FSK Output for Radio 2.
Connector: RCA, Grounded/closed on MARK
TIP – Signal
- (16) POWER:**
Power Switch

4 - INSTALLATION

Installing micro2R consists of several steps:

- 1) prepare micro2R to work with your radios
- 2) install microHAM USB Device Router (the control and interface software)
- 3) configure Router
- 4) set audio levels

Preparing micro2R for Use

1. Make up two cable sets to connect your radios to micro2R.

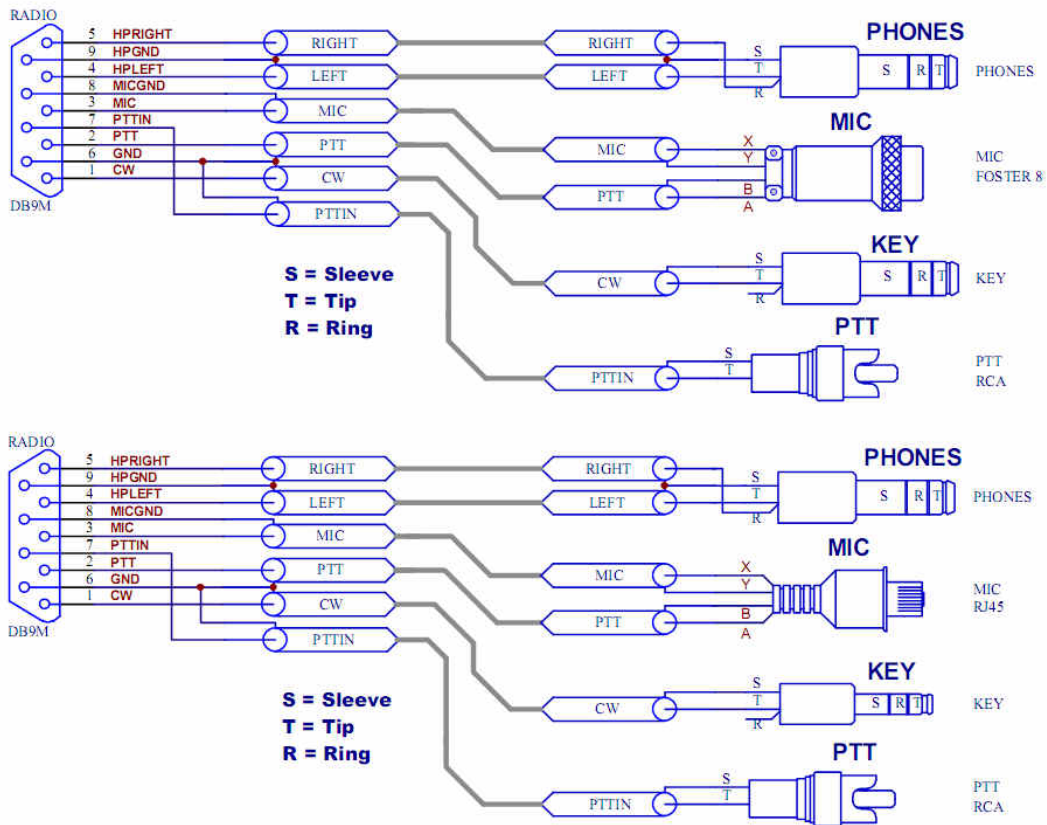

Schematic index	A	B	X	Y
Signal name	PTT	PTTG	MIC	MICG
Mobile Icom (RJ45)	4	7	6	5
Desktop Icom (Foster8)	5	6	1	7
Kenwood TS-480 (RJ45)	5	4	3	6
Kenwood & Elecraft (Foster8)	2	8	1	7
Mobile Yaesu (RJ45)	6	7	5	4
Desktop Yaesu, TenTec (Foster8)	6	5	8	7
TenTec (Foster4)	3	4	1	2

2. Turn off both radios and make micro2R rear panel accessible.
3. Connect the cable from your left hand transceiver to the Radio 1 DB9 jack.
4. Connect the cable from your right hand transceiver to the Radio 2 DB9 jack.
5. Connect cables from PTTIN1 to the PTT out of RADIO1
IMPORTANT: This connection is required for proper audio switching in VOX operation.
6. Connect cables from PTTIN2 to the PTT out of RADIO2
IMPORTANT: This connection is required for proper audio switching in VOX operation.
7. Connect your headset to the Mic and Phones jacks.
8. Connect your paddles to the PADDLE jack.
9. If you use a foot switch or hand PTT, connect it to the FOOTSW jack.
10. Connect the SC OUT jack to the Line Out or Speaker jack of your sound card.
11. Connect the SC MIC jack to the Microphone jack of your sound card.
12. Connect a 12V-16V DC supply to the DC 13.8V jack.
Be sure to observe the proper polarity.

NOTE: Do not use a power supply that is connected to either radio. Using a common power supply for micro2R and a transceiver will permit power supply return currents from the transceiver to flow through the micro2R grounds. As a result of design defects in the microphone circuit of nearly every amateur transceiver, the return currents will generate a voltage in series with the microphone input which will result in unwanted feedback (often called "RFI").

13. Locate the USB cable but **DO NOT connect it at this time.**

Installing *microHAM* USB Device Router



The Windows setup utility will start and ask into which folder Router and its supporting files should be installed. Note: unless you have a very strong reason to install Router elsewhere, please accept the default location.

When the Router installation is completed, click "Finish" to launch Router for the first time. Then plug in the USB cable and proceed to configuring Router for your station and software.

To install Router click on the ***Install USB Device Router*** link on the installation CD or download the most recent installation package from the web site: www.microham.com/contents/en-us/d29.html

If you download an updated package, right click on "urouter_release_xx_xx.exe" (xx_xx is version) and choose "Run as administrator" to start installation.



Configuring *microHAM* USB Device Router

The *microHAM* USB Device Router (Router) program provides a Windows compatible *configuration tool* for *microHAM* USB Devices (micro2R as well as DIGI KEYER, *microKEYER* II, CW Keyer and USB Interfaces) and *software interface* to other Windows applications (logging software, digital mode software, etc.). The software interface is provided as *Virtual Serial Ports*.

In order to configure and use micro2R with Windows compatible application programs, you must have installed the USB driver, started Router, applied power to micro2R and turned the device on. Router is then configured as required by the application (logging, control or digital mode) software.

micro2R includes an LPT (parallel) input. This connection is required for applications which do not support the *microHAM* SO2R Control Protocol or provide focus control information on a serial port.

micro2R Status



When the USB driver is installed correctly and micro2R is turned on Router will show a device tab with a **GREEN** check beside the device name (u2R).



When Router shows a **YELLOW** "X" instead of a green ✓, it means the USB driver is correctly installed but micro2R is not turned on.



When Router shows a **RED** "X" instead of a green ✓, it means the device is disconnected and Router does not see the USB part of micro2R. This happens when the USB cable is unplugged or the USB driver is not correctly installed.

Initial Setup



Router must be used to configure micro2R for proper operation. The device configuration tabs (in the red rectangle) are used to setup each part of the micro2R.

Creating and Using Virtual Serial Ports

microHAM Router provides a set of virtual serial ports which allow Windows applications (logging and digital software) to work with micro2R just as they would work with "real" (hardware) serial ports.

In order to use these virtual Ports, you must first create the ports and then assign a port to each function you wish to use (radio control, PTT, CW, FSK, etc.).

DO NOT define a port that is already in use (for example, COM1 or COM2 which are hardware ports on many motherboards) or a virtual port that is used by another USB device. Even though Router will not allow creating a virtual port on a COM port number which is already present in the system (like hardware COM ports or internal modems), sometimes these ports are hidden. If a device which also uses virtual serial ports (external USB devices, bluetooth devices, mobile phones, PDAs etc.) is not connected to the computer when creating virtual ports in Router, the ports can overlap and will not work properly when you connect such device.

WARNING: Before you begin to create virtual ports, attach all external devices you are using with computer and allow them to be connected to the system. Restart Router and then create virtual ports.

Virtual ports are created on the Virtual Port menu.

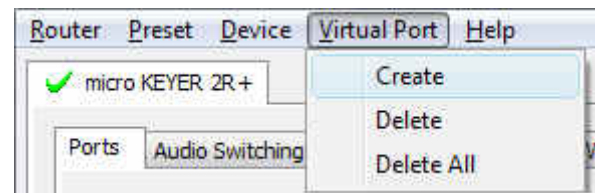
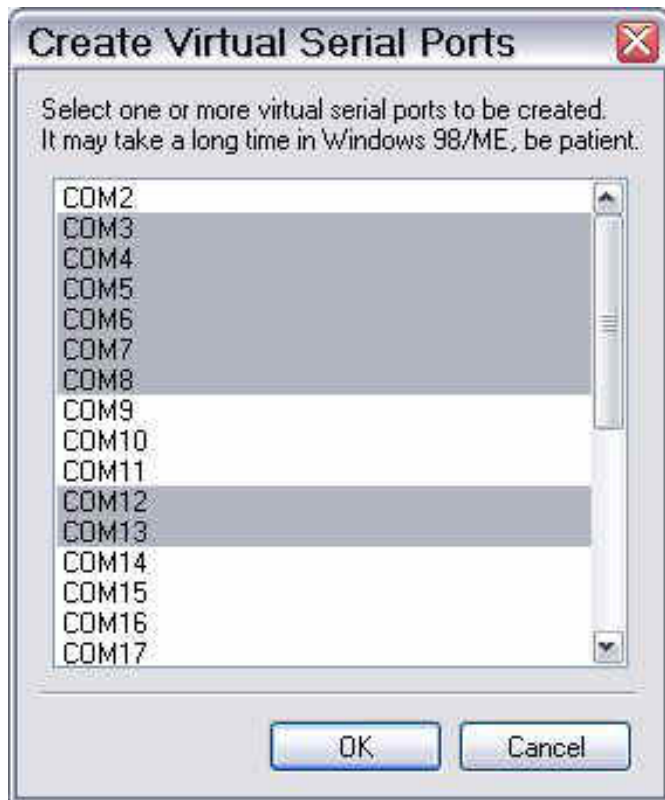

Create - Creates virtual COM ports. It is possible to select more than one port at a time by holding the *Ctrl* key on keyboard and clicking on COM port numbers. Creating virtual ports may take a long time (several tens of seconds), be patient.

Delete - Deletes any single virtual port.

Delete All - Deletes all previously created virtual ports.

Do not delete a virtual port until all applications using that port have been closed.



TIP: It is possible to select multiple ports at one time by holding the *Control* key on keyboard and clicking on the COM port numbers.



TIP: If you have removed another device which used virtual ports and Router does not offer the released COM port number, you will need to reset the virtual port bus. You can do this by deleting all virtual ports in Router at once. Select "Virtual Port | Delete All" then create the ports again. Any missing COM port numbers should appear.

5. microHAM USB DEVICE ROUTER

ROUTER MENU

Default Router Settings: used to completely reset Router to factory (default) settings.

"Default" removes all device tabs and deletes all stored configuration data, including all user presets from the Windows Registry.



TIP: The micro2R can be completely reset by selecting **Default Router Settings** followed by **Device | Store as Power-up Settings** to save the defaults to the controller's EEPROM.

Restore Router Settings: used to restore settings from a *urs* file created by the backup command.

A *urs* file can be used only with the device for which it was generated (the file contains the unit serial number) on a computer with same port assignments.

WARNING: Restoring a backup deletes all current Router settings including presets, **use it carefully!**

Backup Router Settings: used to create backup *urs* file.

This file contains Router settings (including Presets) for all devices defined in Router.

Options | General

Load Router on Start-up: when checked, Router will start automatically each time the computer is started or rebooted.

Start Router Minimized: when checked, Router will started minimized

Options | Band Map: Customizable band edge boundaries used to drive the band data output. BCD codes can be customized for driving antenna switches or bandpass filter control.

Options | Digital Band Map: (Not used with micro2R)

Customizable band boundaries for the digital mode operation. This setting is used to automatically select VOICE or DIGITAL audio switching and the proper PTT output. Careful selection of the "Digital band" is necessary for transceivers which do not have a special mode for AFSK operation or do not report the mode in the computer command set. This primarily effects Kenwood and TenTec transceivers although it applies to some older Icom and Yaesu radios.

Options | Audio Devices:

Don't use audio devices: when checked, Router does not use audio devices and the settings on the Audio Mixer and DVK tabs have no effect.

WARNING: When selected, Router will not be able to control micro2R Audio Mixer and DVK, **use it carefully!**

Manually assign audio devices: when checked, Router will allow the user to select audio devices (sound card) in the appropriate fields of the Audio Mixer tab and will actively control the audio devices

Automatically assign microHAM audio devices: (Not used with micro2R)

when checked, Router will automatically assign proper audio device of the same name if multiple microHAM interfaces of the same kind are connected to the one computer. This setting does not apply to micro2R, it applies only to DIGI Keyer.

Options | DVK:

Voice message time limit: maximum time for each voice message up to 120 seconds.

Sample rate: sampling frequency used during recording and playback of voice messages.

Sample size: sampling size used during recording of voice messages. Sampling size primarily effects audio quality of the messages. 16bit samples provide higher quality than 8bit.

NOTE: Select the same sample rate and size as used by your software to avoid message distortion.

Options | USB:

Noise immunity: selects how many times an undelivered USB packet will be repeated before the USB device is disconnected from the operating system.

Response time: selects how long the USB interface will wait for additional data before sending data to the operating system.

Minimize: Clicking this will minimize Router to the system tray at the bottom right corner of the Windows Task Bar (the "System Notification Area").



TIP: When Router is minimized you can restore it by double-clicking on the Router tray icon. You can also restore Router by double-clicking on the Router icon on the desktop or in the Programs menu.

Exit: Clicking on this item will terminate Router.

NOTE: when Router is terminated the virtual ports will be closed and application software will be unable to communicate with micro2R and the radio.

PRESET MENU

The requirements of each application (logging, control and digital mode programs) are different. Each program handles radio control, CW, FSK, PTT, and the sound card its own way. In some cases, what works for one application may not work properly with another. To get maximum performance from *micro2R*, the user should create customized settings for each application used.

For easy switching among applications, Router supports up to 12 user definable **Presets**. Different configurations can be stored in these presets and recalled almost instantly simply by clicking on the preset button.

Each preset contains the settings for all devices connected to, and controlled by, Router. For example, if Router controls a *microKEYER II*, a USB Interface II and Station Master, each preset remembers the settings for all devices including the assignment of COM ports and the contents of all sub-tabs except the FSK/CW Messages and DVK tabs.

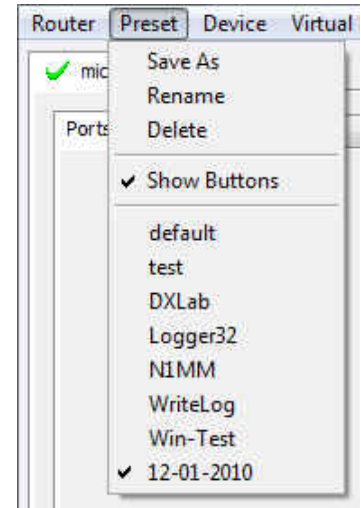

NOTE: Presets are not available until they have been created and saved by the user using **Preset | Save as**. For sample configurations for popular software, refer to the Setup Guide documents available in Router Help menu. Use **Help | Download Documents** if the Setup Guides are not available or incomplete.

There are three ways to apply a preset once it is created:

1. Click on **Preset** and select from the pull-down menu.
2. Click on a preset button. For the buttons to be visible in Router, **Preset | Show Buttons** must be checked. When the settings from a preset are applied, a green light located in the preset button is lit. This green light is on **ONLY** when all settings in Router are same as those stored in the preset.



3. By right clicking on the system tray icon when the Router is minimized.
4. The presets and the current router configuration are stored to the registry when Router is closed and recalled when Router is loaded.

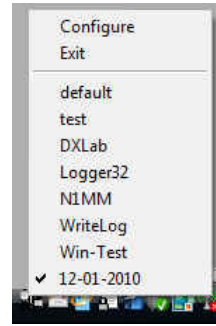

Save as - Saves the current Router settings to a preset for future use.

Rename - Allows renaming of an existing preset.

Delete - Delete chosen preset.

Show buttons - When checked, Router shows the preset buttons.

DEVICE MENU

Router can control several devices. This allows configuring the settings for all (interfaces) connected to the computer at the same time using the Presets.

Each device has its own tab (page) in the main Router notebook. The content of each device tab depends on the type of device. Adding a device is automatic when Router detects a new device. Once detected, a device remains in Router even though device is disconnected. Each device is identified by a unique serial string.



NOTE: Router supports all microHAM USB devices in a single instance by creating a separate root tab for each device. It is not necessary to run multiple instances of Router; a secondary instance can not be started.

Rename – Creates a custom device name. This is useful if two or more devices are connected to the Router. For example CW KEYER and *microKEYER II* can be renamed to more identifiable names as shown here...

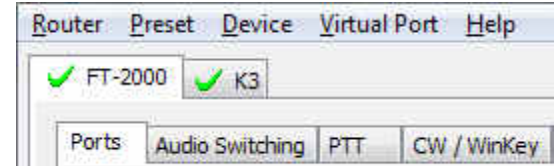

Delete - Removes a device from the Router. Only disconnected devices with a **RED "X"** on device tab can be removed. To disconnect a device from Router, unplug the USB cable from the computer or device.



Save Template - will save the current Router settings to template file.

When clicked, Router will open a standard File Save dialog window – the default location is *C:\Documents and Settings\All Users\Application Data\microHAM\cfg*. If a hypertext (*html*) or plain text (*txt*) documentation file of the same name as the template is present in the same directory, it will be associated with the template.

Load Template – will automatically configure Router from a template (**.tpl* file).

When clicked, Router will open a standard File dialog – the default location is: *C:\Documents and Settings\All Users\Application Data\microHAM\cfg* - and the desired template can be chosen. When Router loads a template, it looks for an *html* or *txt* file with the same name as the template in the same directory. If such file is found, it is displayed.



TIP: Templates are a powerful tool for quickly configuring Router to work with a particular application. Template files are interchangeable between computers and ideal for cloning setups in multi-computer stations or for sharing configurations between users.

Store as Power-Up Settings: - will store the current settings of the Audio Switching, PTT, CW/WinKey, SO2R and ACC tab to the micro2R EEPROM. If micro2R is operated without connection to the computer it will use the settings stored in EEPROM. If micro2R is connected to a computer running Router, the Router settings will be used but the default settings are retained in EEPROM.

Upload Firmware: *microHAM* will occasionally release updates to the firmware in micro2R. The update may support new features in Router or improve application compatibility. The most recent public version of the firmware is always available from www.microham.com/contents/en-us/d29.html

To update firmware, download the firmware file to your computer, then click on **Device | Upload Firmware**. A Windows file dialog will open, navigate to the directory into which you downloaded the firmware file and select the file.

NOTE: If you upgrade Router, each upgrade will include the latest firmware file. The new firmware will be automatically uploaded to the micro2R when the new version of Router connects for the first time, you have just to confirm the upgrade when prompted.

VIRTUAL PORT MENU

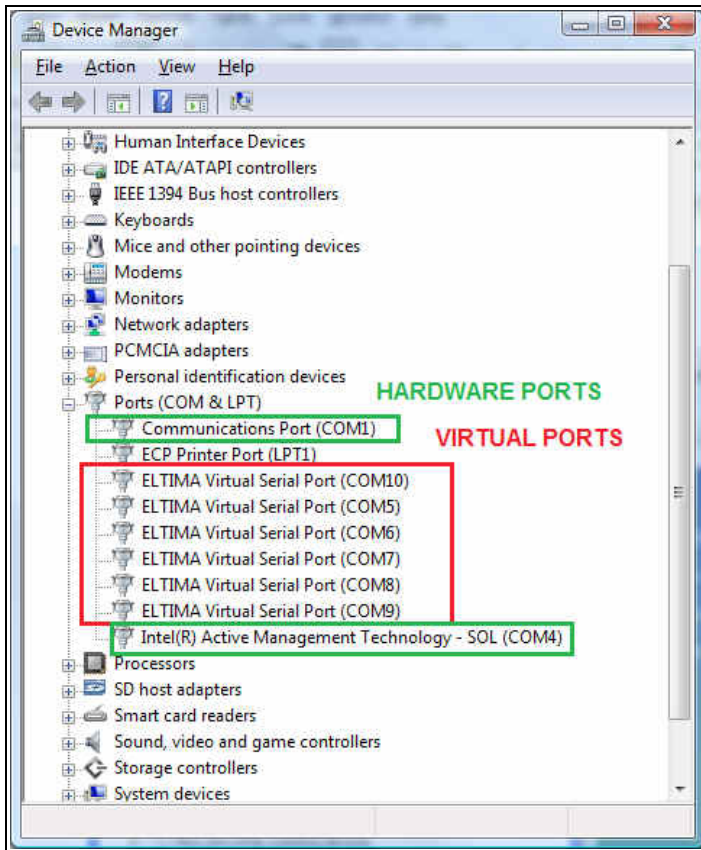

It is necessary to create a number of virtual serial ports (COM ports) in order for a Windows application (logging, control or digital mode program) to access *microHAM* devices.

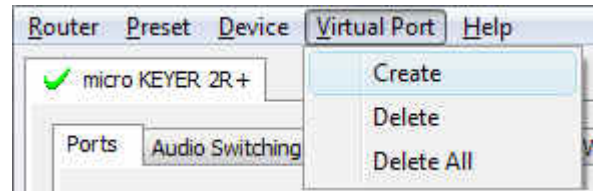

Create - Creates virtual COM ports. It is possible to select more ports at once by holding the *Control* key on the keyboard and clicking on COM port numbers. Creating a virtual port may take a while, be patient.

Delete - Deletes any single virtual port.

Delete All - Deletes all previously created virtual ports and resets Virtual Serial Port bus.

Do not delete a virtual port unless all applications using that port have been closed.

NOTE: Properly working ports should not display an exclamation mark (!).

HELP MENU

Manuals: Link to microHAM manuals located on your system

Setup Guides: Link to software configuration guides for many common applications.

Cable Schematics: Link to cable diagrams.

Download Documents: Downloads microHAM documentation including updated manuals and setup guides. You may specify the products for which you want documentation. This requires an Internet connection.

microHAM Home Page: Link to www.microHAM.com

microHAM Downloads Page: Link to www.microham.com/contents/en-us/d29.html

Show Tooltips: When checked, small, single line help is displayed below the mouse cursor

Update Router: Download and install the most recent version of Router.

About: Shows the Router's internal version number

Change logs: Shows the Router and firmware changes.

DEVICE CONFIGURATION TABS

There are ten (10) tabs for configuring micro2R. Each tab controls part of micro2R's functions. Except for CW Messages, FSK Messages and Functions tabs, any change is applied immediately to micro2R.



- **Ports:** assign virtual ports to the micro2R for use by applications
- **Audio:** configures headphone switching based on operator preference, receive focus and transmit source.
- **Audio Mixer:** sets sound card levels.
NOTE: The Audio Mixer is not available under Vista or Windows 7 and above. Those operating systems do not permit an application like Router overall control of the sound device.
- **PTT & ACC:** configures T/R keying and foot switch functions
- **CW/WinKey:** configures the internal CW keyer
- **CW Messages:** enter/store internal CW message memories
- **FSK Messages:** enter/store internal FSK message memories
- **DVK:** configure and control the level of Router's voice keyer
- **Keyboard:** configure operation of PS/2 keyboard or keypad
- **SO2R:** select source of focus control and other SO2R operating features.

PORTS TAB

Once the virtual ports have been created they must be associated with a specific function or device channel (e.g., Control, CW, PTT, etc.). These assignments should correspond to settings of the application software and must be configured first in Router then in the application.

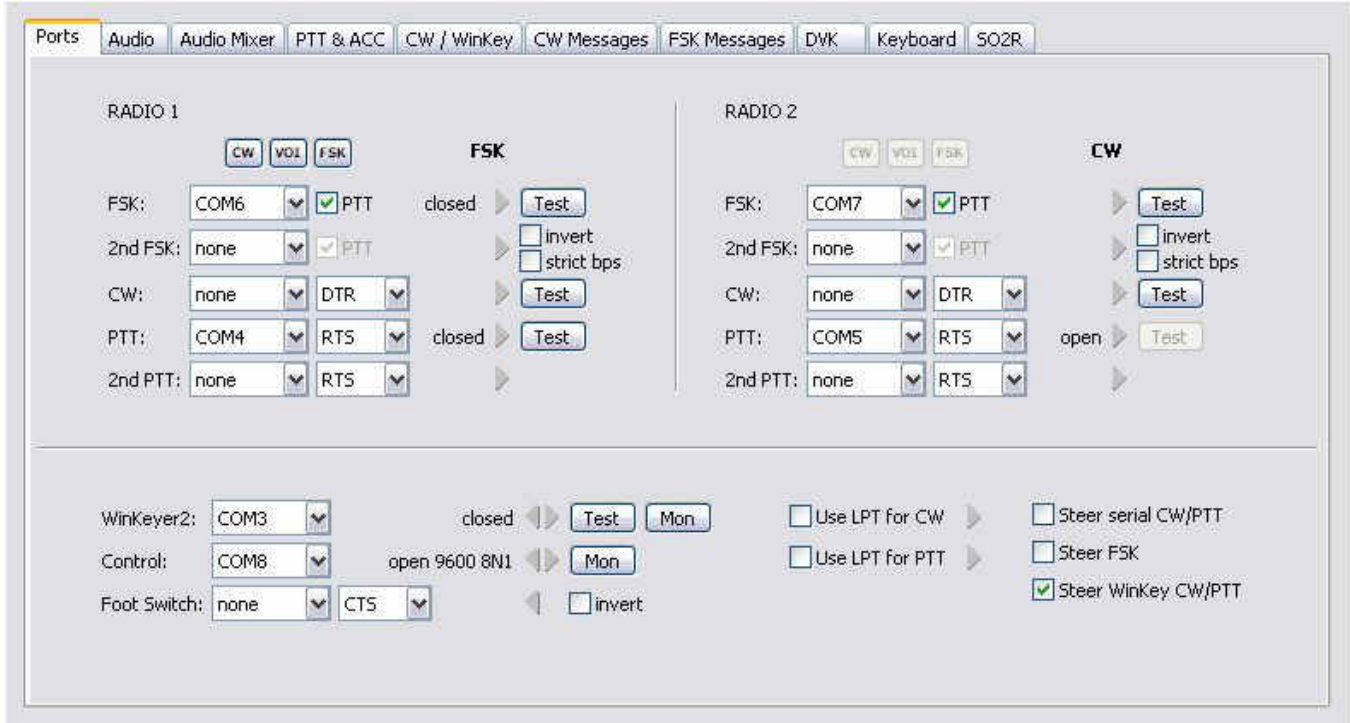

Proper port configuration is critical for operation with application software.

micro2R has eight channels – each channel provides an indication of the settings applied by the application and current state (e.g., on or off).

These eight channels (functions) are available for each radio:

- **FSK** (uses TxD for FSK and RTS for PTT if checked)
- **2nd FSK** (uses TxD for FSK and RTS for PTT if checked)
- **CW** (uses DTR or RTS)
- **PTT** (uses DTR or RTS)
- **2nd PTT** (uses DTR or RTS)

These channels are common to both radios.

- **WinKeyer2** (uses RxD and TxD)
- **Control** (uses RxD and TxD)
- **Foot Switch** (uses CTS, DCD, DSR or RING)

NOTE: Do not assign virtual ports for the channels/functions which are not used by your applications. It is unnecessary and only consumes resources.

FSK & 2nd FSK PORTS

The FSK channel is used by the application program to send the FSK keying signal. FSK is used primarily for RTTY. It is very important to understand the difference between FSK and AFSK.

FSK is a digital (On/Off) signal used in the transceiver to generate a frequency shift. FSK must be supported by the transceiver (this mode is commonly labeled RTTY or FSK).

AFSK is an analog (audio) signal used to modulate the transceiver for digital modes like RTTY, PSK31, AMTOR etc. Computer sound card generated AFSK or PSK does not require special transceiver support and can be used in the LSB, USB or FM mode of the transceiver. Some radios have dedicated modes for AFSK (generally labeled PKT, DATA, LSB-D or USB-D) with special features.

It is very important to properly adjust the audio drive level of an AFSK system so as to not overdrive the first transmit audio amplifier stage in the transceiver and produce a wide, distorted signal, full of intermodulation products. It is important to appreciate that distortion generated at this point due to overdrive CANNOT be reduced or eliminated by the reduction of the microphone gain control – it is the signal level that must be adjusted to be about the same as would be expected from a microphone. The microphone gain control then becomes a form of transmit power control.

An initial indication of proper audio drive level can be seen on the ALC meter of the radio. Provided that there is NO audio processing in circuit and that the microphone gain control is in its normal operating position, then, if the ALC does not show or just starts to indicate during transmission, the signal is likely to be clean. It is also important is to turn off the microphone compressor, ANY transmit audio equalizer, AND transmit DSP when AFSK is used. DO NOT use any form of digital modulation (sometimes called "Transmit DSP") with AFSK or PSK. Some transceivers bypass these circuits automatically when signal is routed to the rear audio jack instead of the microphone jack, but some do not (for example, the TS-850).

Edited by Geoff Anderson, G3NPA

If your transceiver supports FSK, use FSK for RTTY whenever possible. It's the only sure way to get a clean RTTY signal no matter the microphone gain or compressor (processor) settings on your radio.

When a COM port is assigned in Router but not in the application program (or the application is not running), Router will indicate the channel is **closed**.

When an application opens the COM port, Router will indicate the channel is **open** and display baud rate, number of data bits, parity and number of stop bits in use. For example, 45 5N1.5 means: 45 Baud, 5 data bits, no parity, 1.5 stop bits.



The 2nd FSK port is useful when operating split with radios that have two receivers (e.g., FT-1000, FT-2000, FT-9000, K3, Orion or IC-7800). The second instance of the RTTY program should specify "right channel" for its audio source and should be configured to use the 2nd FSK port for its FSK output.

The 2nd FSK port can also be used for a second RTTY program with a different decoding algorithm to provide diversity decoding and transmit from either program.



TIP: If you see a baud rate other than 45.5 baud (e.g., 4800 or 9600), the application is NOT configured correctly for FSK RTTY operation.

PTT: The virtual port used for FSK can also support PTT (required by MMTTY). When you use MMTTY, select the PTT box and RTS will be used for PTT. Do not use the FSK port for any other function.

Invert: Some transceivers lack the ability to set the sense of the FSK input. If you cannot set the proper sense, check the invert box. This is normally necessary only with the TenTec Omni V, Omni VI and Kenwood TS-940.

Strict bps: Some programs rely on the the UART "buffer full" signal for proper PTT timing and drop PTT (unkey) when the UART buffer is empty. Because virtual ports generally have two buffers - one in the USB driver and one in the hardware - the first buffer may empty before all of the data has been transmitted allowing the PTT to before the message is complete. 'Strict bps' disables the USB buffering and sends one character at a time to the FSK output. With "Strict BPS" selected, the output will be about 10% slower due to the presence of extra stop bits between characters but proper PTT operation will be assured.

NOTE: DO NOT select strict bps for MMTTY, USB option C provides accurate timing.

To test FSK operation from the computer to the radio, click the **Test** button with no port selected or the port closed. The Test button will generate "RY" two times.

NOTE: Select RADIO1 or RADIO2 (as needed) with the TX R1/R2 button on micro2R when testing.

CW PORT

By its very nature, USB is not well suited to transfer the real time events required for CW keying. In addition to the latency inherent in the USB protocols, there are also latencies caused by computer CPU load, internal Windows message processing (inter-process communication) and data flow from another peripherals sharing same the USB hub. This can result in transmitted characters that are garbled. To minimize these unwanted operating system effects Router uses a specially developed oversampling and prediction algorithm to assure the smoothest possible transfer of control signal events over USB. Using this principle, CW keying in the Router is, in most cases, usable up to 50 WPM if the application generates keying signals accurately and does not consume 100% of CPU time at the highest priority class.

Router allows assigning a virtual serial port for software CW using DTR or RTS signals. DTR* and RTS* are identical to DTR/RTS except that the output is inhibited for one second after the COM port is opened. RTS*/DTR* should only be used with programs that cause unwanted key-ups during startup.

NOTE: the CAT port may be used for CW if is provided by a microHAM interface.



TIP: More applications use DTR for CW than RTS.

When an application opens the COM port (usually at start-up), Router will indicate the channel is **open**.

The state of the CW channel is indicated by a red arrow. If port is opened, it does not mean that it is properly configured. The red arrow will light in time with the transmitted CW when the port is properly configured.



To test CW operation, click on the **Test** button with no port selected or the port closed.

NOTE: Select RADIO1 or RADIO2 (as needed) with the TX R1/R2 button on micro2R when testing.

PTT & 2nd PTT PORTS

The PTT channels are used to control transmit/receive switching of the transceiver and power amplifier. An internal sequencer assures 100% protection against hot switching of the PA when the PTT channel is used. More information about T/R switching and the sequencer is provided under the PTT tab.

Router allows assigning virtual serial ports for PTT using the DTR or RTS signals. DTR* and RTS* are identical to DTR/RTS except that the output is inhibited for one second after the COM port is opened and should only be used with programs that cause unwanted key-ups during startup.



TIP: More applications use RTS for PTT than DTR.

The state of the PTT channel is indicated by a green arrow. If the port is opened, it does not mean it is properly configured. When the port is properly configured, the arrow will light during the entire transmission. To test PTT operation, click on the **Test** button with no port assigned or the port closed.

The screenshot shows a configuration panel with two rows. The first row is labeled 'PTT:' and contains a dropdown menu set to 'none', a dropdown menu set to 'RTS', a green arrow icon, and a 'Test' button. The second row is labeled '2nd PTT:' and contains a dropdown menu set to 'none', a dropdown menu set to 'RTS', a green arrow icon, and a 'Test' button.

The 2nd PTT channel is identical to the primary PTT channel. 2nd PTT provides a way for a second application to key the radio if the primary application also controls PTT – for example, a logging program and CW reader/keyboard.

NOTE: the CAT port may be used for PTT if it is provided by a microHAM interface.



TIP: Always use serial PTT instead of the radio command PTT or VOX. It is the only way to assure proper sequencing of a Power Amplifier, LNA or receive antenna switch.

To test PTT, click on the **Test** button with no port selected or the port closed.

NOTE: Select RADIO1 or RADIO2 (as needed) with the **TX R1/R2** button on micro2R when testing.

WinKeyer2

WinKeyer2 is the next generation of the unique external CW processor developed by Steve Elliott, K1EL: WinKey with integrated dual radio support. This CW processor supports paddle input like any other electronic keyer, is highly configurable, and converts input received in ACSII (text) format to Morse characters. This unique property assures perfectly timed CW output regardless of operating system load. More detailed instructions for configuring WinKey are found in the description of the CW/WinKey tab.

When a COM port is assigned to WinKey in Router but not in the application program (or no application is running), Router reports the channel as **closed**.

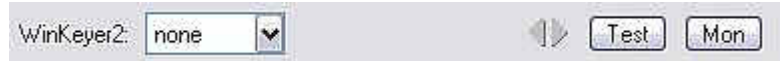

When an application opens WinKey 2, (usually at start-up), Router reports port as **open** and displays settings used to configure COM port.

 **TIP:** If you see settings other than 1200 8N2, the application is not configured correctly for WinKeyer2. Even if the application sets an incorrect data rate, Router will send data to WinKey at 1200 baud but reliable operation is not guaranteed.

Data flowing through the channel are indicated by two arrows. The green arrow indicates data flow from the application to WinKey and the red arrow indicates data flow from WinKey to the host application.

Test: Sends "Test" via Winkey2 if a port is not selected or is closed.

NOTE: Select RADIO1 or RADIO2 (as needed) with the TX R1/R2 button on micro2R when testing.

Mon: "WinKey Monitor" allows capturing communications between Router or the application and WinKey2. Controls for the monitor include **Start**, **Stop**, **Clear** and **Save**.

WinKey Monitor should not be used under normal conditions. However, if there are problems with WinKey and a logger, it may be useful to **Start** a capture and close the window. When a problem is noticed, the window can be opened and the WK communications log **Saved** for analysis.

WinKey Monitor is circular – only the last 20 kilobytes or so will be saved in order to prevent creating very large files.

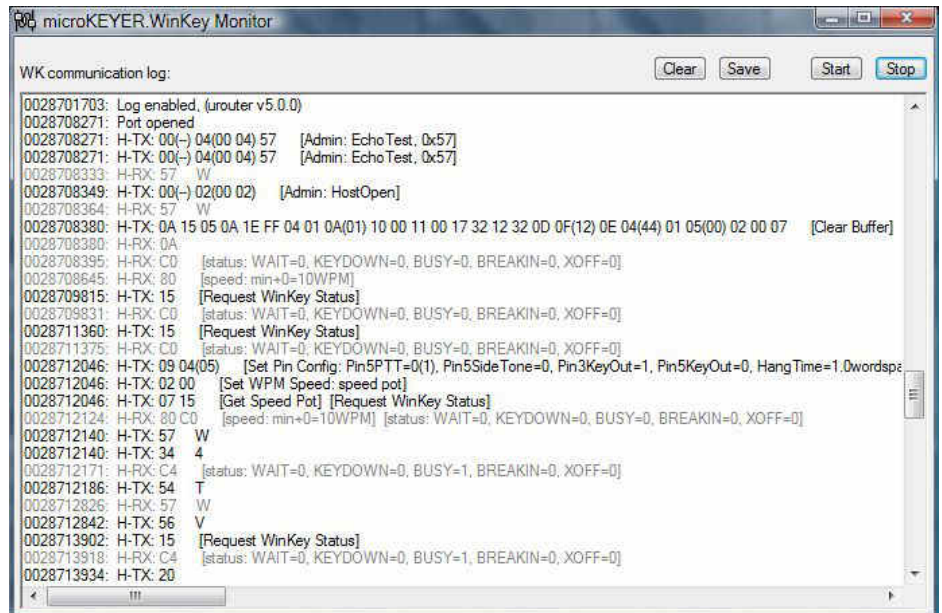

WK Monitor will display a description of each command from Router or the application and "decoded" response from WinKey. " If a line ends in three dots (...) it means that the command or response has been broken across two USB packets.

CONTROL PORT

The Control Port allows an application program (logger) that implements the microHAM Control (SO2R) Protocol to operate micro2R completely with only a single USB connection. The microHAM SO2R Control protocol allows a logger to specify Transmit Focus, Receive Focus, Stereo/Split headphone as well as control antenna switching and optionally use the CW, FSK and voice memory functions.

When an application opens the control port, Router reports port as **open** and displays settings used to configure COM port.

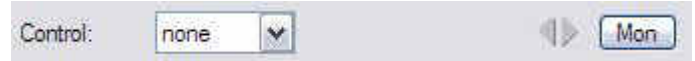

Data flowing through the channel are indicated by two arrows. The green arrow indicates data flow from the application to WinKey and the red arrow indicates data flow from WinKey to the host application.

Mon: Opens a “Control Protocol Monitor” window to capture microHAM SO2R Protocol communications between a logger and Router. Controls for the monitor include **Start**, **Stop**, **Clear** and **Save**.

The Control Protocol Monitor should not be used under normal conditions. However, if there are problems between a logger and Router, it may be useful to **Start** a capture and close the window. When a problem is noticed, the window can be opened and the Control protocol log **Saved** for analysis.

The monitor log is circular – only the last 20 kilobytes or so will be saved in order to prevent creating very large files.

The monitor will display a description of each command from the application and the response from Router. If a line ends in three dots (...) it means that the command or response has been broken across two USB packets.

FOOT SWITCH

Router allows assigning a virtual serial port to the foot switch channel and selecting one of four available input control lines (CTS, DCD, DSR or RING).

NOTE: CTS is not available if the foot switch channel is shared with the radio control port. The state of the signal on the virtual port can be inverted by checking **inverted box**.

When a COM port is assigned for the foot switch but the application does not support foot switch status (or no application is running), Router reports the channel as **closed**.

When an application opens the COM port (usually at start-up), Router reports channel as **open**.

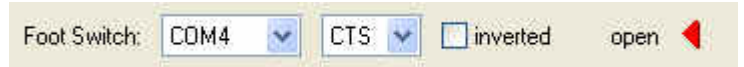

When the foot switch is pressed, this state is indicated by a red arrow.

CW and PTT from LPT (parallel port)

micro2R includes an LPT interface for "CT/NA compatible" CW and PTT inputs. When the "Use LPT for CW" box is checked, micro2R will accept CW input on pin 16 of the LPT input. The red arrow indicates when LPT CW is active (key down).

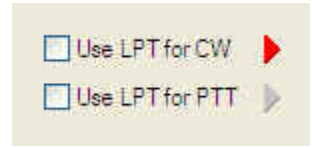

When the "Use LPT for PTT" box is checked, micro2R will accept PTT input from pin 17 of the LPT. The red arrow indicates when LPT PTT input is active.

NOTE: Never enable more than one CW source at a time. You must select which source (WinKey, Serial or LPT CW) will be used by micro2R. Selecting multiple sources will result in distorted CW output.



TIP: If you plan to use micro2R with DOS based software, check "Use LPT for CW" and "Use LPT for PTT" and save that selection using "Device | Store as Power-up Settings" from the Router menu.

CW/PTT steering

When manual control of transmit focus is selected in micro2R, CW (including WinKey) and PTT signals will be redirected to the active (selected) radio. This function was implemented to avoid confusion and assure the "expected" behavior. This means that CW and PTT signals for both radios will be directed to the selected (active) radio.

Some logging programs do not support two radios or are designed to generate only one set of keying signals which are connected to the selected radio using a steering (A/B) control. Selecting "Steer serial CW/PTT" will allow Router and micro2R work properly with those applications.



When steering is enabled, the Serial CW, Serial PTT and 2nd PTT channels for RADIO1 are used for both radios. The active radio will be selected based on the "steering" control signal (**TX focus**) defined on the SO2R tab.

Steer FSK

Some applications, particularly day-to-day logging programs like DX4Win do not support simultaneous operation of two radios but they do permit switching radios.



Steer FSK permits switching the FSK output from the MMTTY engine used by these loggers to the selected radio. When FSK steering is enabled the RADIO_1 FSK and 2nd FSK ports will also be used for RADIO_2. The active radio will be selected based on the "steering" control signal (**TX focus**) defined on the SO2R tab.

Steer WinKey CW/PTT

Some applications like DXLab Suite, DX4Win and WriteLog use the original WinKey protocol even though they support multiple radios. This limits WinKey to a single CW output with no "two radio" support.

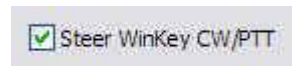

Steer WinKey CWPTT allows micro2R to steer the "RADIO 1" CW and PTT outputs of WinKey 2 to the active radio based on the "steering" control signal (**TX focus**) defined on the SO2R tab.

AUDIO TAB

Understanding Sound Card operation in Amateur Radio programs

Each sound card has two sets of controls - *PLAYBACK* and *RECORDING*. For most cards these settings are independent and can be controlled by the application software, the user (from Windows *VOLUME CONTROL* application), or both. To understand the operation of these controls, it is recommended that you conduct the following tests:

- Connect headphones to the sound card output and connect a microphone to the sound card microphone jack.
- Open the *VOLUME CONTROL* application (click Start | Run and type *SNDVOL32* if you do not see a speaker icon in the System Tray area of the Task Bar).
- If your system has more than one sound card installed click *Options | Properties* and select the sound card you are using. Then select "Playback" and enable ALL controls to be displayed.
- Leave the *PLAYBACK VOLUME CONTROL* running and open second instance of *VOLUME CONTROL*. Arrange them on the desktop so both are visible at the same time (later you can run your logging software and watch for interactions). In the second instance of *VOLUME CONTROL*, click *Options | Properties*, choose the same sound card as you chose for the *PLAYBACK VOLUME CONTROL*, select "Recording" and enable ALL controls.
- Now you have both *PLAYBACK VOLUME CONTROL* and *RECORDING VOLUME CONTROL* on your desktop.
- Confirm that you have a "Microphone" channel in the *PLAYBACK* window. If not, your sound card will not support "live mic" mode. You will need to upgrade your sound card to make use of those functions.
- Now *UNMUTE* all controls in the *PLAYBACK* window. If you speak to the microphone, you should hear your own voice in headphones. You can control level with the microphone slider or master volume slider. This is because sound card has *INTERNAL LOOPBACK* from the microphone input to the sound card output *ENABLED*. If you *MUTE* microphone control in the *PLAYBACK* window, loopback will be disabled and you will hear nothing.
- This function is used by software to mute the microphone during message (F1-Fn) *PLAYBACK* and avoid mixing noise from the microphone with message. During playback, the microphone is muted; after the message is completed the microphone is unmuted allowing *VOX* operation.

NOTE: Manipulating the microphone controls (slider or select/mute box) in the *RECORDING* window has NO effect because you are NOT recording. The recording controls are used only used when the logging software is recording (Ctrl-Shift-Fn or Control-Fn) a message as a WAV file. To record, the *RECORDING* mic control MUST be selected. The logging program usually handles this function automatically.

micro2R allows customizing the audio configuration to meet the needs of a specific logging program and operating style (*VOX*, foot switch, computer generated transmit/receive switching, etc.).

There are two distinct audio paths in micro2R and each path can be switched independently:

- from the transceiver headphone output to the operator headphones
- from the sound card or microphone to the transceiver mic input.

From transceiver headphone outputs to the operator headphones.

micro2R allows flexible audio selection of from both radios. Audio from the transceiver headphone jack is connected to the micro2R headphone input, (optionally) passed through a switching relays which select the audio source connected to each earphone and allow the user to select a variable level of mixing from one ear to the other.

The audio connections can be defined for each transmit and receive state. The audio selection is indicated by the RX Focus LEDs on the front panel.

The **RX R1 (16)** and **RX R2 (17)** buttons allow fast, manual selection of Radio1, Both (Split/Mix), or Radio 2 audio.

When the **RADIO1** and **RADIO2** buttons are pressed simultaneously and held for more than .5 seconds, the AUTO light will illuminate and micro2R will switch to the **AUTO** switching mode. The AUTO mode recognizes six (6) states and STEREO "priority" state:

- RADIO1=RX & RADIO2=RX & RX focus=R1
- RADIO1=RX & RADIO2=RX & RX focus=R2
- RADIO1=COMPUTER TX & RADIO2=RX
- RADIO1=RX & RADIO2=COMPUTER TX
- RADIO1=MANUAL TX & RADIO2=RX
- RADIO1=RX & RADIO2=MANUAL TX
- STEREO - set by the logging software.

HEADPHONES			
	R1	BOTH	R2
RX focus on R1	<input checked="" type="radio"/>	<input type="radio"/>	<input type="radio"/>
RX focus on R2	<input type="radio"/>	<input type="radio"/>	<input checked="" type="radio"/>
Computer TX on R1 (Latch)	<input type="radio"/>	<input type="radio"/>	<input checked="" type="radio"/>
Computer TX on R2 (Latch)	<input checked="" type="radio"/>	<input type="radio"/>	<input type="radio"/>
Manual TX on R1	<input checked="" type="radio"/>	<input type="radio"/>	<input type="radio"/>
Manual TX on R2	<input type="radio"/>	<input type="radio"/>	<input checked="" type="radio"/>
STEREO	<input type="radio"/>	<input checked="" type="radio"/>	<input type="radio"/>

The "Stereo" state overrides all other states.

Receive audio (headphone) selections can be set using the "Headphones" panel on the Audio tab. The audio source (Radio 1 Left/Right, Radio1 Left/Radio 2 Left, Radio 2 Left/Right) for each state is selected using the radio buttons and becomes effective immediately.

NOTE: Separate switching for TX and Computer TX (Latch) is enabled/disabled using the front panel LATCH button.

Headphone ground loop isolation.

Even when both radios are properly grounded it is possible to get a hum in the headphones. This hum can be caused by differences in headphone ground potential between the radios. micro2R keeps the headphone ground of each radio isolated from the other as well as from the u2R ground. However, when dual receive (stereo/split) is selected the headphone grounds must be connected together.

To avoid the possibility of a ground loop in this situation micro2R includes isolation transformers in line with each headphone channel from radio2. These transformers are enabled by default but can be bypassed by moving five jumpers as shown in the picture.

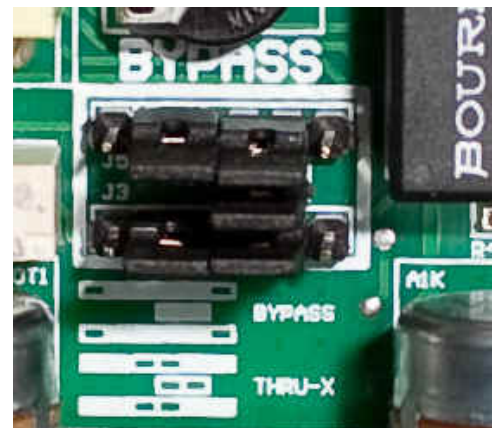

NOTE: While the Isolation transformers have excellent IMD and saturation parameters, they also have up to 2dB loss. You may need to increase the volume on radio2 to get the same level as when the headphones are connected directly to the radio.

From the sound card and microphone to the transceivers.

Audio to the transceivers can come from two sources - from the computer sound card or from the microphone. Due to the unique microphone handling in micro2R, the microphone signal can go to the sound card and to the transmit audio selection circuit at the same time.

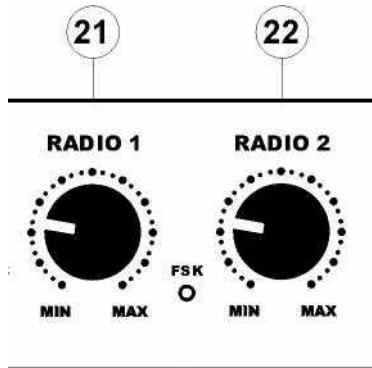

By default, when “Disable audio switching on RADIO1/2” boxes are **not checked**, the microphone is connected to the radio which has TX focus. The transceiver microphone input is disconnected from the operator microphone and switched to the sound card output only when the computer initiates transmission and generates a PTT signal.

The transmit audio level is set by the RADIO1 and RADIO2 pots on front panel. These pots control only the audio generated by (or passing through) the computer sound card.

In VOICE mode there are two operating configurations:

1. When the **Disable audio switching on RADIO1/2** check box is **unselected** audio from the microphone is connected to the transceiver which has TX focus. Sound card output is switched to the microphone jack only for DVK playback when the computer generates a PTT signal through the virtual serial port, WinKey, microHAM protocol or LPT port.
2. When the **Disable audio switching on RADIO1/2** check box is **selected** audio from the microphone is disconnected from transceiver but remains connected to the sound card. The sound card output is connected to the transceiver input all the time.

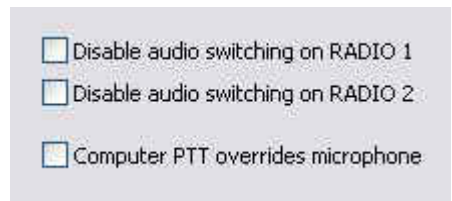

NOTE: To use this configuration your sound card **MUST** support local microphone echo described at the beginning of this chapter.

Computer PTT overrides microphone: When checked, audio from the sound card will override the microphone even if footswitch is depressed. "Restore serial PTT and audio routing" must be selected on the PTT tab to prevent audio from the sound card from being disabled when the footswitch is released.

Sound Card: shows the Name, Mixer ID, Wave In ID and Wave Out ID for each input/output in the computer. The ID numbers are necessary to configure some applications (for example: WSJT, MMVARI etc.).

NOTE: Audio Switching is set independently for RADIO1 and RADIO2. Be sure to configure both!

PTT & ACC TAB

The PTT tab provides independent PTT configurations for each radio.

PTT INPUTS

micro2R has six PTT inputs for each radio:

- PTT generated by the logging program on the virtual COM port RTS or DTR
- 2nd PTT generated by a second application on the virtual COM port RTS or DTR
- PTT generated on the DTR line of the FSK channel if the PTT box is checked.
- PTT generated on the DTR line of the 2nd FSK channel if the PTT box is checked.
The PTT and FSK channels generate the same **Serial PTT** input (they are logically in parallel).
- The foot switch attached to the micro2R rear panel RCA jack.
The foot switch PTT will be applied to the radio with transmit focus.
- WinKey generated PTT.
Depending on the mode used by the logging program, WinKeyer2 can generate a separate PTT signals for each radio or a single PTT that can be applied to the radio with transmit focus.

NOTE: when WinKey2 is controlled by a logging program, the program configuration determines whether WinKey generates one or two PTT signals.

PTT OUTPUT

micro2R has one PTT output for each radio located on pin 2 of the RADIO1 and RADIO2 connectors.

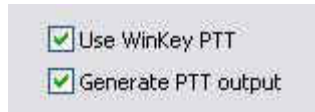

Use WinKey PTT: If unchecked, micro2R ignores the PTT from WinKey2.

Generate PTT Output: When checked, micro2R generates a PTT output in response to the PTT inputs. When unchecked, micro2R does not generate any PTT output (e.g., VOX/QSK operation).

PTT lead: Specifies lead-in delay.

With WinKey2, PTT lead is the time between PTT activation and the first CW output.

With Serial PTT (PTT, 2nd PTT, FSK and 2nd FSK) and the foot switch, In VOICE and FSK/DIGITAL, PA PTT and LNA PTT lead transceiver PTT (PTT1 or PTT2) by the amount of PTT lead.

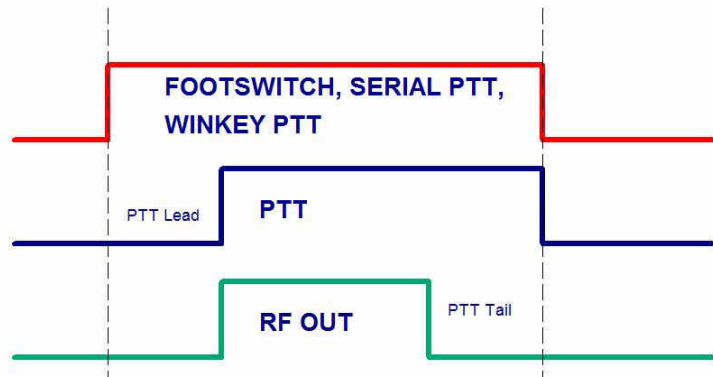

PTT tail: Defines how long PTT remains closed after the last CW character. PTT tail can be set to a constant value or can vary between seven (1.00 word space) and ten (2.00 word space) dot lengths proportional to the CW speed.

R/T delay: Defines the transceiver switching time from receive to transmit if PTT signal is issued at the beginning of the switching sequence.

FOOT SWITCH SEQUENCER

Additional functions can be associated with the foot switch (or hand mic PTT). micro2R recognizes when the foot switch is closed (pressed) or open (released).

micro2R can mute or block serial port CW, FSK, PTT and audio when the foot switch is activated. Each of those

When foot switch is pressed	When foot switch is released
<input checked="" type="checkbox"/> Mute serial CW <input checked="" type="checkbox"/> Mute serial FSK	<input type="checkbox"/> Restore serial PTT and audio routing <input type="checkbox"/> Restore serial CW <input type="checkbox"/> Restore serial FSK

inputs can be selectively restored when the foot switch is released or can remain muted until all PTT inputs are released.

Mute serial CW - if checked, virtual port CW (DTR or RTS) output generated by an application program will be muted while the foot switch is closed. If **Restore serial CW** is checked, CW will resume when the foot switch is released (if it has not already ended). If **Restore serial CW** is not checked, application generated CW will remain suppressed until the application releases PTT.

Mute serial FSK - if checked, FSK generated by an application will be suppressed while the foot switch is pressed. If **Restore serial FSK** is checked, FSK will resume when the foot switch is released (if it has not already completed). If **Restore serial FSK** is not checked, FSK will remain suppressed until the application releases PTT.

Restore serial PTT and audio - if checked, application generated serial PTT will be restored and audio routing will return to the “serial PTT” setting when the foot switch is released. If **Restore serial PTT and audio** is not checked, audio will only return after the application releases PTT.

CW/WinKey TAB

This tab provides the configuration for the internal, WinKey2 based, CW keyer. A complete WinKey2 manual can be downloaded from: <http://k1el.tripod.com/files/WinkeyUSBman.pdf>. Thanks to Steve Elliott, K1EL for this great product.

WinKey2 can be controlled by a logging program or operate in stand alone mode controlled by Router. Router controls the speed range, Paddle mode and other timing characteristics of Winkey2. When an application opens WinKey2, Router plays no part in buffer handling and speed control. All other settings remain under Router control, application settings are discarded to avoid timing issues and to keep WinKey behavior consistent across applications.

NOTE: WinKey parameters are stored separately for each Preset. This allows quick selection of parameters by choosing different preset. The Paddle swap parameter can be also controlled from attached PS/2 keypad.

WARNING: Do not change parameters while an application (logger) actively accessing WinKey.

When WinKey2 is closed, the basic operating parameters can be adjusted on this tab. Every change is applied immediately.

Paddle Mode

- Iambic A (Curtis)
- Iambic B (Accu-Keyer)
- Ultimatic (Single lever)
- Bug Keyer (Vibroplex emulation)

NOTE: To connect a straight key to MKII, use "Bug Keyer" mode. The straight key should be connected between ring and sleeve of a three conductor plug. The tip must be open.

The screenshot shows the following settings in the Paddle Mode configuration window:

- Paddle mode:** Iambic B (Accu-keyer)
- Priority:** dit dah
- Paddle setpoint:** 50 %
- Disable paddle memory
- Swap paddles
- Auto space
- CT space
- Speed pot min:** 15 WPM
- Speed pot max:** 40 WPM
- Farnsworth speed:** 0 WPM
- DIT / DAH =** 100 / 300
- Weighting:** 50 %
- Allow logger control

Priority – Ultimatic mode offers a choice if DIT or DAH priority for dual lever paddles. If no priority is selected, the keyer works in a "last paddle wins" mode.

Paddle set point - controls when WinKey begins looking for a new paddle press after sensing the current one. The default value is one dit time (50) and is adjustable in percent of a dit time.

Disable paddle memory – When checked, DIT (or DAH) insertion is disabled.

Swap paddles - Reverse paddle sense for left handed operation or improperly wired paddle.

Auto space - Keyer generates automatic character space.

CT space - Selects "contest" word space (six elements long instead of seven).

Speed pot min/max - Min/Max value of the front panel speed knob (9) in range 5 to 99 WPM.

Farnsworth speed – Sets the Farnsworth keying speed (10 to 99 WPM range, 0 disables this feature).

DIT / DAH - DIT/DAH ratio from 1:2 to 1:4 in hundreds. Accepted numbers are from 200 to 400.

Weighting - Weighting in percentage (from 10 to 90%).

Allow logger control: - Special setting for diagnostics. **Do not use** unless instructed to do so by the factory.

CW MESSAGES TAB

On this tab you can define nine CW messages of up to 50 characters each which are stored in EEPROM. Each memory may have a programmable repeat delay and/or call another memory.

Message content	Jump to	Delay [s]	Test on CW
1 W4TV	-	0	Test Store
2 DE W4TV	-	0	Test Store
3 TU 5NN	-	0	Test Store
4 CQ TEST DE W4TV W4TV	-	0	Test Store
5 55N	-	0	Test Store
6 5NN	-	0	Test Store
7 CQ CQ DE W4TV W4TV	-	0	Test Store
8	-	0	Test Store
9	-	0	Test Store

Par: 5
Set WPM 05
Set Key 05
Set Wait 05

Merge
Cancel WPM

Store All

Load from File
Save to File

Commands which may be included in a memory are:

- Merge:** merge two characters without a letter space – [M]AS will sound AS .-...
- Cancel WPM:** restore speed set by the Speed pot.
- Set WPM:** force speed to the selected value regardless of position of speed knob.
- Set Key:** close CW output for selected time in seconds.
- Set Wait:** wait selected seconds during playback.

- Jump to:** used for looping a message or calling another message
- Delay:** sets the delay in seconds before looping or calling another message

- Test:** plays a message without storing it
- Store:** saves one message to micro2R memory

- Store All:** saves all messages to micro2R memory

- Load from File:** loads all messages from file
- Save to File:** saves all messages to file

Messages can also be saved and replayed using an external keyboard or numeric keypad attached to the PS/2 jack. See: External Keyboard.

NOTE: Messages are not saved or loaded with Presets.

FSK MESSAGES TAB

On this tab you can define nine FSK messages of up to 50 characters each which are stored in EEPROM. Each memory may have a programmable repeat delay and/or call another memory.

Message content	Jump to	Delay [s]	
1 W4TV	-	0	Store
2 [CR]DE W4TV	-	0	Store
3 TU 5NN	-	0	Store
4 [CR]CQ TEST DE W4TV W4TV	-	0	Store
5 55N	-	0	Store
6 5NN	-	0	Store
7 [CR]CQ CQ DE W4TV W4TV	-	0	Store
8	-	0	Store
9	-	0	Store

Commands which may be included in a memory are:

CR & LF: Insert Carriage Return/Line Feed

Figure: Insert special Figure character

Letter: Insert special Letter character

Blank: Insert special Blank character

Letter: Insert special Bell character

Jump to: used for looping a message or calling another message

Delay: sets the delay in seconds before looping or calling another message

Store: saves one message to micro2R memory

Store All: saves all messages to micro2R memory

Load from File: loads all messages from file

Save to File: saves all messages to file

Messages can also be saved and replayed using an external keyboard attached to the **PS/2** jack. See: External Keyboard.

NOTE: Messages are not saved or loaded with Presets

DVK TAB

micro2R allows recording and playing nine voice messages per bank and an unlimited number of banks (limited only by the capacity of the computer hard disk). Banks can be managed with Rename, Add and Remove buttons. **Rename** to rename the current bank, **Add** to create a new bank, and **Remove** to delete the current bank. Bank selection is provided by **Bank** box.



Each memory may repeat with a programmable delay (loop) or can be chained with another memory using external keyboard or keypad.

While a DVK message is recorded or played micro2R uses the DVK mixer settings. When recording or playback is done, the settings in the Audio Mixer are restored. DVK mixer settings are not stored with presets but in the message banks. This means each bank can have its own levels (slider position). It also allows each bank to be configured for the voice of a different operator if micro2R is used in a multi-operator station.

DVK memories can be played back using the LPT signals (DVK 1-4 or DVK 1-6) generated by many programs for controlling external DVK units. The external control signals are defined on the SO2R tab.

Set :

REC MIC: "Microphone (USB Voice CODEC)"

TX: "Speaker (USB Voice CODEC)"

REC MIC slider adjusts microphone level during message recording.

TX controls the DVK playback level.

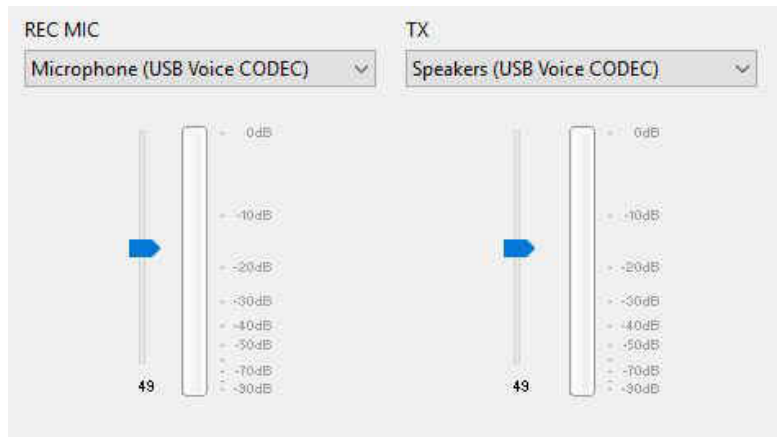

KEYBOARD TAB

The Keyboard Tab controls the operation of a PS/2 keyboard or numeric keypad connected to the PS/2 jack. It is also possible to define control functions for the numeric keypad. Custom controls are invoked by pressing and holding the asterisk key (*) with Numkey0-9.

General:

QWERTZ layout – configures the keyboard for a QWERTZ layout.

FSK from keyboard:

Diddle LETTERS: send the LETTERS character whenever there is nothing in the transmit buffer.

UOS: shift back to LETTERS case whenever a space is encountered in the transmit data.

Type ahead: enables type ahead when using a PS/2 keyboard. Characters are transmitted after a **space** (word mode) or when the buffer has reached its limit (16 characters).

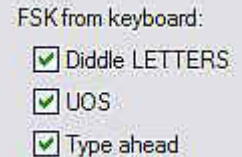

CW from keyboard:

Type ahead: enables type ahead when using a PS/2 keyboard. Characters are transmitted after a **space** (word mode). or when the buffer has reached its limit (16 characters).

Speed Step: set the amount by which the Up/Down or NUM +/- keys change the CW speed.

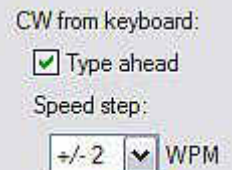

Auto numbering:

Leading zero as T: sends leading zeros in contest report as T. For example 001 will be send as TT1.

Zero as T: sends all "zeros" in contest report as T. For example number 100 will be send as 1TT.

One as A: sends all "ones" in contest report as A. For example number 101 will be send as AOA.

Nine as N: sends all "nines" in contest report as N. For example number 199 will be send as 1NN.

Report 5NN: send 5NN before contest serial number.

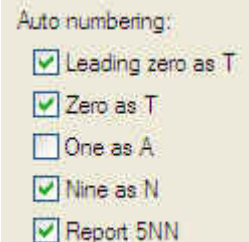

The **PS2** and **FH-2** sub tabs allow assigning control functions to PS/2 and FH-2 style keypads. FH-2 connects to pins 2 and 3 of the PS/2 jack. microHAM does not supply an adapter for FH-2 keypad.

NOTE: An FH-2 cannot be connected to the transceiver and tomicro2R at the same time.

SO2R TAB

The SO2R Tab is used to configure the signals each program uses to convey Transmit Focus, Receive Focus and Stereo (Split) headphone states to micro2R.

Computer AUTO Control:

If micro2R is in AUTO TX Focus and AUTO RX Focus, radio selection is under software control. micro2R provides three ways for the application to control focus: "Classic auto control" (CT/NA compatible) using the parallel (LPT) port, DTR and RTS signals on one or more serial port, or by software command (microHAM Control Protocol).

NOTE: Software developers who would like to implement control of microHAM products including micro2R using microHAM Control Protocol should contact [OM7ZZ](mailto:OM7ZZ@microham.com) at microham.com.

CLASSIC AUTO CONTROL is flexible tool for customizing micro2R for operation with legacy software. There are four (4) parameters which can be controlled via parallel port (CT/NA compatible LPT) or virtual serial port DTR and RTS signals.

TX focus: Used for automatic selection of the transmitter.

Available signals are:

- LPT pin 3
- LPT pin 14
- COM port RTS signal
- COM port DTR signal
- Two PTTs

Each signal can be inverted if necessary. The state of the signal is represented by a RED arrow.

RX Focus: Used for automatic headphone "priority" switching when both radios are in receive.

Available signals are:

- LPT pin 4
- COM port RTS signal
- COM port DTR signal
- Follow TX Focus

Each signal can be inverted if necessary. The state of the signal is represented by a RED arrow.

"Follow TX focus" is a special setting for applications that provide only TX Focus control. Headphone audio is selected automatically based on the TX Focus.

Stereo Headphones: Forces stereo headphone (split) mode regardless of operating state.

Available signals are:

- LPT pin 5
- LPT pin 9
- COM port RTS signal
- COM port DTR signal

Live Status:

Shows the current TX Focus, RX Focus and STEREO status

RED 1 circle represents RADIO1 and GREEN 2 circle represents RADIO2

Semi-automatic focus control:

When checked, RX Focus will follow TX Focus if TX focus is manual and RX Focus is "Auto." Any focus command from the logging program will be ignored while TX Focus is in Manual (Radio 1 or Radio 2).

OPERATION:

TX logic: micro2R supports two modes of operation - first one wins or last one wins. In **first one wins**, transmitting on one radio will lock out transmission on the second radio. In **last one wins**, beginning a transmission on one radio will abort a transmission in progress on the other radio.

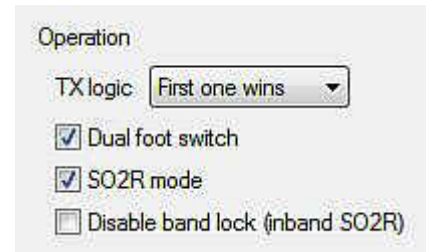

SO2R mode: If checked, simultaneous transmission on both radios is not allowed. When not checked, the radios can transmit at the same time.

Warning: You are violating contest rules and etiquette if you enter a single operator or multi-operator single transmitter class with the SO2R mode disabled. ALWAYS observe contest rules !!!

Disable band lock (in band SO2R): In order to prevent accidentally transmitting with both radios on the same band, micro2R will normally inhibit transmission when both radios are on the same band as determined by the Band Data, Antenna Select or Band Relay commands from logging software.

NOTE: Band Lock is not available with LPT or serial port (DTR/RTS) control or with software that does not provide continuously updated Band Data/Band Relay signals.

WARNING: Disabling band lock may allow damage to the transceiver front end.

6 - micro2R OPERATION

Setting Audio Levels

For optimum operation of micro2R the audio levels must be set properly. The function of each control was described in the AUDIO MIXER and DVK sections of the manual.

About microphones and micro2R: In order to configure micro2R correctly, it is absolutely necessary to understand the difference between electret and dynamic microphones.

A dynamic microphone consists of a small moving coil and a magnet. As sound moves the diaphragm, the magnetic field in the coil changes producing a very small AC current which results in about 15 millivolts peak-to-peak at the of the typical transceiver. If a small voltage is applied to a dynamic microphone, it requires more sound pressure to move the diaphragm and the output of the mic is reduced. If the current through the coil is not limited, a dynamic mic can be damaged.

An electret mic consists of a capacitor with an electrostatically charged dielectric attached to the diaphragm and a small amplifier. The voltage variation caused by sound on the electret capacitor is so small that the amplifier is required before the output can be used. The amplifier requires a small DC voltage ("bias") to operate and provides an audio signal of about about 500 millivolts peak to peak.

While dynamic and electret microphones each have their strong points, they are not directly interchangeable. Where an electret mic will not work without a DC supply, a dynamic mic can be damaged by that voltage. In addition, signal levels are very different with the typical electret mic producing signal levels 20-60 times greater than that from a dynamic mic. Because of the differences, one can not interchange dynamic and electret microphones without special consideration.

Most amateur transceivers are designed for use with dynamic microphones - this includes those made by Elecraft, Kenwood, TenTec and Yaesu. On the other hand, Icom transceivers are designed for use with electret microphones. When compared to other transceivers, Icom radios typically required a larger audio input and have a DC voltage on their microphone line. Note: the Elecraft K3 can be configured for either electret or dynamic microphones.

Configuring micro2R for your radios:

1. Open the top cover of micro2R and check the jumper for the internal microphone preamplifier. Jumper has three pins. For dynamic microphones, so not close any pins. For electret microphone that require bias on TIP (mono plug like Heil iC), place a jumper on the top two pins (**TIP** position). For electret microphones with stereo plug that expect to have bias on the ring (a typical computer or multi-media microphone), place a jumper on the lower two pins (**RING** position).
2. Set the **R1** (Radio 1) and **R2** (Radio 2) microphone trimmers (located above headphone isolation jumpers) and the preamp **GAIN** trimmer (located above the microphone jumper) to the middle of their range.
3. Set the front panel TX1 and TX2 knobs to 12 o'clock.
4. Connect your microphone to micro2R and select Radio 1 for transmit.
5. Open Router's Audio tab and uncheck both "Disable audio switching on RADIO1" and "Disable audio switching on RADIO2." Make sure the VOICE mode has been selected on the Ports tab.
6. On the PTT tab, set "Generate PTT output" for both radios.

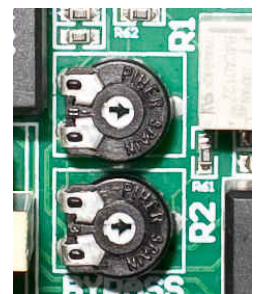
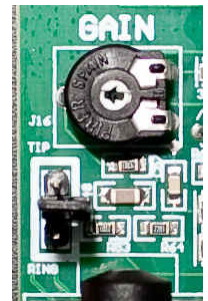

7. Set TX Focus to Radio 1 using the **TX R1/R2** button.
8. Set your radio to USB or LSB, connect it to a dummy load and switch RADIO1 to transmit. Set the MIC GAIN control on RADIO1 to the same position as you use when the microphone is connected directly to the radio. While speaking into microphone adjust the R1 trimmer to set proper drive level (this should be your normal operating level). When finished, do not touch the MIC GAIN control again.
9. Set TX Focus to Radio 2 using the **TX R1/R2** button.
10. Set your radio to USB or LSB, connect it to a dummy load and switch RADIO2 to transmit. Set the MIC GAIN control on RADIO2 to the same position as you use when microphone is connected directly to the radio. While speaking to microphone adjust the R2 trimmer to set proper drive level. (this should be your normal operating level). When finished, do not touch the MIC GAIN control again.

Setting audio levels:

1. Open Router's Audio tab and check both Disable audio switching boxes.
2. Click the "Sound Card" button.
3. On the "Audio Devices" window select the sound card connected to the micro2R in the Mixer and WaveOut.
4. Click the TX Mixer button. If the Mixer does not appear, open the Windows Sound Control Panel and select the "Playback" tab.
5. Click the "Test Signal" button on the Audio Devices screen and verify that the VU Meter for the selected sound card in the Sound Control Panel reaches maximum. If not, turn off the Test Signal, restart Router and return to step 2. Turn off the Test Signal.
6. Close the Audio Devices window but leave the Sound Control Panel open.
7. Select the "Playback" tab in the Sound Control Panel.
 - double click "Speakers" for the sound card attached to micro2R
 - click Levels tab and unmute both Speakers and Microphone
 - click Balance and set LEFT and RIGHT to 70%, then click OK
 - Preset the Microphone level to 70%
8. Select the "Recording" tab in the Sound Control Panel
 - double click "Microphone" for the sound card attached to micro2R
 - click Levels tab and unmute the Microphone
 - Preset the Microphone level to 70%
9. While speaking into the microphone, adjust the Microphone level until you see the top green bar light on the VU meter for the selected sound card on the Recording tab, then click OK. If level is too low or too high adjust the **REC** trimmer (located behind the sound card jacks) as needed.
10. Return to the Playback tab, double click the selected sound card, select the Levels tab and adjust the microphone to the same level you set in the previous step.
11. Set TX Focus to Radio 1 using the **TX R1/R2** button.

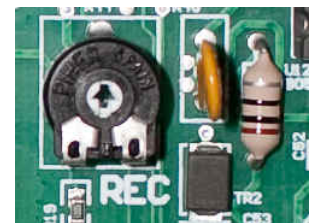

12. Turn on VOX or press the MOX/transmit switch on the radio and speak into the microphone. Using LEFT and MICROPHONE sliders set the same drive level as you set in step 8 at the top of page 42. Do not adjust the preamp GAIN trimmer, R1 trimmer or MIC gain knob on radio. If you cannot set the correct drive level, adjust the front panel RADIO1 knob.
13. Set TX Focus to Radio 2 using the **TX R1/R2** button.
14. Turn on VOX or press the MOX/transmit switch on the radio and speak into the microphone. Using RIGHT slider set the same drive level as you set in step 10 at the top of page 42. Do not adjust the TX MIC slider, preamp GAIN trimmer, R2 trimmer or MIC gain knob on radio. If you cannot get the correct drive level, adjust the front panel RADIO2 knob.
15. Set TX Focus to Radio 1 using the **TX R1/R2** button.
16. On the DVK tab in Router, select default bank and set REC MIC and TX to 70%. Press the "Record" button and adjust the REC MIC so that signal does not peak into to the red area.
17. Press the "Play" button and check that the drive level is same as you set in step 11. If not, adjust the TX level.

NOTE: Under Vista and Windows 7 and above, DVK levels are separate from those set by other applications. DVK levels are stored with the message banks which permits each operator to customize the DVK for his own voice.

18. The voice settings are now complete.

NOTE: For digital operation (AFSK/PSK31), set micro2R mode to FSK and keep all levels as set above. Use ONLY the front panel RADIO1/RADIO2 controls to adjust for proper drive levels (maximum power, no ALC reading).

Understanding Transmit (TX) Focus

micro2R allows changing transmit focus several ways. The **R1/R2** lights indicate which radio will transmit in response to a PTT signal.

Manual TX focus mode

In manual mode, focus (selecting which radio will transmit) is fully under operator control - the computer CAN NOT change focus. The operator can select the active radio (change focus) by tapping the **TX R1/R2** button. If micro2R is in AUTO mode, pressing the **TX R1/R2** button will cancel AUTO mode and at the same time move TX focus to the selected radio.

In manual mode, micro2R will redirect all CW, FSK, PTT, WinKey and DVK signals to the “active” radio (the radio with transmit focus) even when the signal was assigned to the other radio.

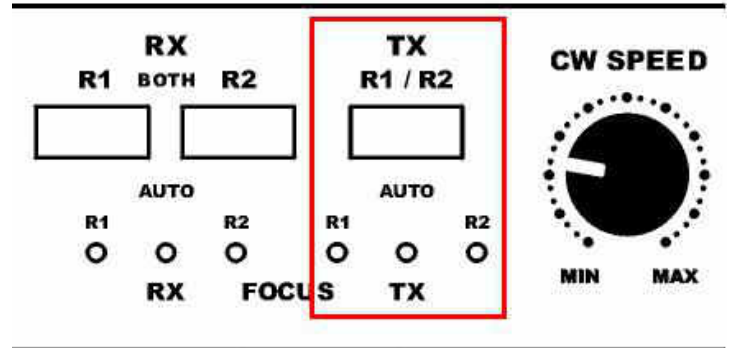

AUTO TX focus mode

In AUTO mode, focus (transmitter selection) is controlled by the logging program. **AUTO** mode is selected by a long press (more than 0.5s) of the **TX R1/R2** button. AUTO mode is indicated by AUTO light. The software can control TX focus in several ways (Parallel port [LPT] signals, a virtual COM port signal, or by using the microHAM SO2R Control Protocol) depending on the **TX focus** configuration on the **SO2R** tab.

Understanding Headphone Switching

Like transmit focus, headphone switching (receive focus) can operate in **MANUAL** or **AUTO** modes.

Manual headphone switching

In manual mode the operator can select what he wants to hear using the **RX-R1** and **RX-R2** buttons.

RX-R1 selects audio from radio1 to both ears in stereo as provided by the transceiver.

RX-R2 selects audio from radio2 to both ears in stereo as provided by the transceiver.

A short press (less than 0.5 second) of **RX-R1** and **RX-R2** simultaneously will switch the main receiver audio (tip of the headphone jack) of radio1 to the left ear and the main receiver audio (tip of the headphone jack) of radio 2 to the right ear.

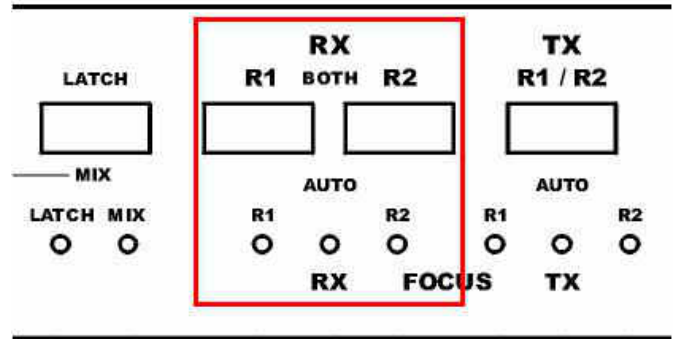

AUTO headphone switching

Automatic headphone switching is a unique and powerful feature of the micro2R. By using programmable States, micro2R provides the maximum level of flexibility to customize headphone switching. Switching micro2R to AUTO headphone switching mode is accomplished by pressing the **RX-R1** and **RX-R2** buttons at the same time for more than 0.5seconds. AUTO mode is indicated by the AUTO light. A short (less than 0.5 second) press of **RX-R1**, **RXR2**, or **BOTH** at any time will exit AUTO mode (return to manual control).

The micro2R AUTO mode operates based on six “operating” states and one “priority” state. A different, operator defined, headphone switching configuration can be applied for each state. Transmit focus, the transmit/receive state of each radio, Receive Focus and “STEREO” (or SPLIT) are used to control headphone switching. The interface by which the logging program communicates these additional signals can be configured on the SO2R tab in Router.

micro2R recognizes these states:

- State 1:** Both radios receiving, RADIO1 has RX Focus
- State 2:** Both radios receiving, RADIO2 has RX Focus
- State 3:** RADIO1 is switched to transmit by computer (serial PTT, WinKey, or Protocol).
- State 4:** RADIO2 is switched to transmit by computer (serial PTT, WinKey, or Protocol).
- State 5:** RADIO1 is switched to transmit manually (Footswitch, paddles, or VOX).
- State 6:** RADIO2 is switched to transmit manually (Footswitch, paddles, or VOX).
- Stereo:** Priority “stereo” state. Special “Stereo” settings are applied when logging program indicates “stereo” or split operation.

For proper automatic operation, the desired configuration must be defined for each applicable state. This can be accomplished by selecting the radio/configuration on the "Audio" tab.

NOTE: AUTO headphone switching (receive focus) and AUTO transmit switching (transmit focus) can be enabled independently.

Understanding Interlocks

micro2R provides several forms of interlock and timing protection. When a radio is locked, micro2R immediately disables PTT to the "locked" radio. PTT remains disabled as long as the condition that generated the lock continues.

There are two locks:

- Transmit interlock (or "SO2R mode")
- Same Band lockout

Transmit interlock: is enabled by selecting the **SO2R mode** check box on the SO2R tab. Transmit interlock can be "first one wins" or "last one wins." If selected, simultaneous transmission on both radios is not allowed. When not checked, the radios can transmit at the same time. This lock works independently of any logging software.

Same Band Lockout: disables both radios if micro2R detects two radios on the same band. When the same band lockout is activated transmission on both radios is immediately disabled. and the **TX AUTO** LED will start flashing. Transmission will be enabled when one radio is moved to another band.

NOTE: Same Band Lockout functions **ONLY** with logging software that provides BCD band data to the ACC port of micro2R using microHAM protocol.

System Considerations

micro2R can be used with a wide variety of software applications. The capabilities of those packages will have a large impact on the level of computing power needed to utilize micro2R.

When used with Windows based contest logging applications like N1MM Logger Plus, Win-Test, and WriteLog or Windows based general logging applications like DXBase, DXLab Suite, DX4Win, Logger 32 and others, the microHAM control and interface application "*microHAM Router*" must run with the application. Since both the logging program and microHAM Router are real-time applications, system performance will be dependent on both CPU speed and the amount of available RAM.

While *microHAM Router* may run on slower computers, the minimum tested system is a 1.8 GHz Core2Duo processor, Windows 7, 1 GB RAM, CD-ROM, and USB 1.1 port. Whether Router can run as designed on slower machines with less memory and leave enough resources for application programs has not been determined. *microHAM Router* is not supported on any 16 bit version of Windows (95, 98, ME, SE).

In order to provide sufficient performance for simultaneous operation of *microHAM Router*, a logging application, Internet connectivity and other accessory programs, the recommended system is a 2 GHz or faster multi-core CPU with Windows 8.1 or later, 4 GB RAM, CD-ROM, root USB 2.0 port, and a transceiver with supported control protocol and logger, control, or digital mode software. A parallel port is desirable for "classic" interface applications.

EXTERNAL KEYBOARD/KEYPAD

NOTE: The keyboard/Keypad must be a native PS/2 device. A USB device with PS/2 adapter will not work properly.

micro2R includes the ability to generate FSK or CW, record and play CW, FSK or VOICE messages using a PS/2 keyboard or numeric keypad connected to the PS/2 jack. A numeric key pad is sufficient to record and play CW and DVK messages, control CW speed (WPM) or play a serial number message. "Live" CW or FSK (RTTY) requires a full keyboard.

Switching modes:

The keyboard or keypad can be used to switch Router's operating mode (DVK/CW Keyer/RTTY Keyboard). The keystrokes used to select mode are defined on Router's Keyboard tab.

<i>STATUS INDICATION</i>				
<i>NUM</i>	<i>CAPS</i>	<i>SCROLL</i>	<i>play/rec</i>	<i>mode</i>
OFF	x	x	playback	
ON	x	x	recording	
x	OFF	OFF		CW
x	ON	OFF		FSK
x	ON	ON		VOICE

Playing messages:

A message is started by pressing F1-F9 on the keypad or 1-9 on the number pad. A message can be aborted with the ESC key or the zero key on the number pad. Messages may be made to repeat (loop) by pressing DEL (period) on the number pad while the message is playing. The default (minimum) wait time after ending a message and starting again is one second. The pause time may be set from 1 to 9 seconds by entering the desired delay immediately after pressing DEL. For example, 1 5 will start message number 1 and cause it to repeat with five a second delay. Pressing zero (0) will terminate a message loop.

Recording messages:

Recording is started (and stopped) by pressing NUM LOCK. To start recording, press NUM LOCK followed by the number of the message to be recorded. To abort a message without saving, press zero on the number pad or Escape. To end recording and save the message press NUM LOCK.

In CW, micro2R stores characters as they are echoed from the internal WinKey2: only those characters actually transmitted are stored. However, CW messages may be recorded from either paddles or the keyboard. The gap "]" and other WinKey commands cannot be entered from the keyboard but may be used in messages loaded from Router's CW/FSK Messages tab.

In FSK, all characters entered from the keyboard are stored.

<i>std. key</i>	<i>Numeric Keypad</i>			<i>CW mode</i>	<i>FSK mode</i>	<i>Voice mode</i>
	NUM LOCK		start/stop recording of message (recording mode is indicated by NUM LED)	✓	✓	✓
	NUM *		Tune (can be canceled by keys NUM 0 or ESC, or by the paddle)	✓		
ESC	NUM 0		playback: stop transmitting (message or any characters in buffer)	✓	✓	✓
			recording: abort recording without storing the message			
F1-F9	NUM 1 – NUM 9		playback: start message playback	✓	✓	✓
			recording: set message number			
	NUM DEL		playback: periodically repeat last message (default interval is 1 second, it can be changed by pressing the number on number pad)	✓	✓	✓
			recording: no function			
	NUM /		Switch between "speed control mode" and "serial number mode" (serial number mode is indicated by SCROLL LED, if present)	✓		
ALT			When held allows setting the serial number			
PG UP	NUM +	WPM control	Increase CW speed (step defined by configuration)	✓		
UP		S/N mode	Increment number by one without transmitting	✓		
PG DN	NUM -	WPM control	Decrease CW speed (step defined by configuration)	✓		
DN		S/N mode	Decrement number by one	✓		
HOME	NUM ENTER		WPM control	Reset CW speed to pot (knob) value	✓	
ENTER			S/N mode	Transmit number with optional report and increase number by one (format defined by configuration)	✓	
ENTER			transmit CR and LF characters		✓	
F10			Toggle PTT – alternative to foot switch	✓	✓	
CAPS LOCK			Switch between CW mode and FSK mode (FSK mode is indicated by CAPS LED)	✓	✓	
SPACE			transmit space (if "type ahead" mode is active all buffered characters are transmitted before this space)	✓	✓	
			transmit gap (one-half dit delay time), this character cannot be recorded to a message from keyboard – it may only be entered from Router	✓		
0-9 a-z "#\$%&'()*+,-./:;<=>?@\			transmit character, if "CW type ahead" mode is active character is pushed to type ahead buffer to be transmitted after next space. Note: some special characters are mapped to standard prosigns (see WinKey manual)	✓		
0-9 A-Z !"#\$%&'()*+,-./:;<=>?@\			transmit character, if "FSK type ahead" mode is active character is pushed to type ahead buffer to be transmitted after next space		✓	

7 - HARDWARE SPECIFICATIONS

USB: USB 2.0 Full speed, USB 1.1 compatible

Power consumption:

USB – less than 100mA

Power supply – less than 250mA at 13.8V (max. 16V)

CW: 2 x open collector, max 30V/400mA

PTT: 2 x open collector, max 30V/400mA

PTTIN: 2 x active when closed to ground, max load: 1mA at 5V

ACC port pins 2-13: TTL levels, max 4mA load

LPT port: Optically isolated inputs, load less than 1mA per port at 5V

FSK: 2 x open collector, max 30V/400mA

FOCUS: open collector, max 12V/50mA, closed to ground when TXFOCUS=R1

FOOTSW: input active when closed to ground, max load: 1mA at 5V

PHONES: stereo output for headphones, 32 ohm load

MIC: dynamic/electret microphone input, max. 500mV p-p
switchable 8V bias off/tip/ring, max. 1mA

SOUND CARD OUT: AC coupled stereo input from sound card. 32-600 Ohm, max. 4V p-p

SOUND CARD MIC: AC coupled output to sound card microphone input. 600 Ohm, typ. 100mV p-p

Dimensions: **W** 232mm (9.125") x **H** 44mm (1.73") x **D** 105mm (4.125")

Weight: 1.3 kg (1.875 lbs.)

8 - PACKAGE CONTENTS

The product includes micro2R™, USB cable and CD-ROM containing the microHAM USB Device Router program and documentation.

If the shipment is incomplete, please contact us at the following address:

E-mail: support@microham.com

fax : +421 2 4594 5100

by Post: **microHAM s.r.o.**
Nadrazna 36
90028 Ivanka pri Dunaji
SLOVAKIA

9 - WARRANTY

microHAM warrants this product for three (3) years. The product must not be modified in any way or the warranty is voided. Cables are warranted against defects in materials and workmanship for a period of 60 days.

What is covered: During the warranty, *microHAM*, s.r.o., will repair or replace defective product at their sole discretion. You must send the unit postpaid with a copy of the original invoice to the distributor from whom you purchased the product. *microHAM* will pay return shipping.

What is not covered: This Limited Warranty does not cover (1) correction of installation or software errors in the user's computer(s), (2) damage caused by misuse, negligence, user modifications or failure to follow the user manual, (3) connection to improper or excessive voltage or voltage surges, (4) the incorrect installation of any cables connected to the device by the user or (5) weather related storm, lightning or electrostatic discharge damage.

microHAM USB Device Router (the software) is provided "as is" without guarantee of compatibility with any specific operating system, computer, peripheral or accessory.

microHAM assumes no liability or responsibility for damage to other devices or injuries to persons as a consequence of using our products.

If the terms of the above warranty are not acceptable, return the unit, all associated documents and accessories in the original unopened package, prepaid, to microHAM or to your supplier for refund less shipping and a restocking fee.

DECLARATION OF CONFORMITY



**Federal Communications Commission
Statement (USA)**

This device complies with Part 15 of the FCC Rules. Operation is subject to the following two conditions: (1) this device may not cause harmful interference, and (2) this device must accept any interference received, including interference that may cause undesired operation.



European Union Declaration of Conformity

microHAM, s.r.o. declares that the products:

Product Name: micro2R

Conforms to the following Product Specifications:

EN 55022: 1998 Class B following the provisions of the Electromagnetic Compatibility Directive 89/336/EEC

APPENDIX A – CONNECTORS

RADIO 1, RADIO 2 - DB9

Pin #	Label	Description
1	CW	CW output "open collector"
6	GND	Connected to system ground and case
2	PTT	CW output "open collector"
7	PTTIN	active when closed to ground, max load: 1 mA at 5V
3	MIC	Microphone signal output
8	MIC GND	Microphone ground
4	HPL	Left headphone input
9	HPG	Headphones ground
5	HPR	Right headphone input

PS/2 – miniDIN 6

Pin #	Label	Description
1	PS/2 DATA	TTL PS/2 DATA line
2	RESPAD	Input for resistive keypad (FH-2), max.+5V/1mA
3	GND	Connected to the system ground and case.
4	+5 V	+5V output, max.100mA.
5	PS/2 Clock	TTL PS/2 CLOCK line
6	WinKey Button	Connected to WinKeyer2 chip pin 13
SHELL	GND	Connected to system ground and case

ACCESSORY - DB25

Pin #	Label	Description
1	NC	N/A
14	NC	N/A
2	TX FOCUS R1	Output, TTL levels, max 4mA load, active high
15	NC	N/A
3	TX FOCUS R2	Output, TTL levels, max 4mA load, active high
16	NC	N/A
4	NC	N/A
17	NC	N/A
5	NC	N/A
18	GND	GND
6	R1 BAND DATA A	Output, TTL levels, max 4mA load, active high
19	GND	GND
7	R1 BAND DATA B	Output, TTL levels, max 4mA load, active high
20	NC	N/A
8	R1 BAND DATA C	Output, TTL levels, max 4mA load, active high
21	NC	N/A
9	R1 BAND DATA D	Output, TTL levels, max 4mA load, active high
22	NC	N/A
10	R2 BAND DATA A	Output, TTL levels, max 4mA load, active high
23	NC	N/A
11	R2 BAND DATA B	Output, TTL levels, max 4mA load, active high
24	NC	N/A
12	R2 BAND DATA C	Output, TTL levels, max 4mA load, active high
25	NC	N/A
13	R2 BAND DATA D	Output, TTL levels, max 4mA load, active high
SHELL	GND	GND

APPENDIX B – RFI Considerations

A few guidelines to eliminate problems caused by RFI:

1. Proper grounding of all electronic equipment is critical. A modern station contains many, diverse, types of interconnected and interrelated equipment: transceiver, power amplifier, computer, control boxes, switch boxes, and power supplies. Each of these must be individually grounded with a separate connection to a single common ground point, thus forming a star ground connection.

Proper grounding of computers, both "desktop" and laptop is often overlooked. A separate ground connection should be run from the computer to the station common ground point. The best place to ground a computer is a screw with a good connection to the case. On a laptop, this is often the retaining screw on a D-sub connector (e.g, VGA output); on a "desktop" it is often the screws holding the power supply.

It is absolutely important to prevent ground currents from flowing to the common ground point by way of the signal cable. If you use a microHAM "keyer," a good test is to remove the DB15/DB37 connector and USB cable from the keyer and measure the resistance from the shell of the DB15/DB37 to the shell of the USB cable. There should be NO MORE than FIVE (5) Ohms (and preferably less than TWO Ohms) between them.

Note: many PC manufacturers fail to provide an adequate connection between the shell of the USB connector and the PC case. If this is the case, a connection can be established by bridging a folded piece of aluminum foil between the shell of the USB connector and the PC case.

2. Power all your equipment from a single wall outlet. The "safety ground" often exhibits excessive noise between power outlets - sometimes often due to other equipment powered from the same branch circuit. It is always better to avoid this source of noise/interference. It is also a good idea to check the power distribution for loose connections, reversed neutral/ground, open ground and other wiring problems.
3. Sometimes, the USB cable can be a source of RF interference - the cable might have inadequate shielding or the transceivers in PC might be improperly designed causing data flowing inside the cable to be reflected as a common mode current on the shield of the cable. This common mode current can radiate a significant "digital noise." If this is the source of your problems, it can be significantly reduced or eliminated using ferrite chokes on both ends of the cable. Two or three turns through a #31 mix FT240 toroid are better than the common snap-on ferrites of unknown mix.
4. Often, another cause of RFI problems is a common mode current flowing along the antenna feedline into the shack. It is a common misconception that the only thing required of a feedline is that it have low SWR. Unfortunately, a low SWR does not guarantee low common mode current. These common mode currents are conducted into the shack where they can radiate from the feedline, induce currents in any nearby metal object, and/or be conducted into the interconnected equipment. Common mode currents on a feedline are indicated by problems that differ in intensity from one band to another or from one end of the band to another, by problems that change when a feedline is moved or its length changed, where the problem moves from one piece of equipment to another based on band, and/or where the severity changes with transmit power level. The solution is to use common mode chokes to prevent the current from entering the shack. This topic has been given thorough treatment in recent works by W1HIS and K9YC.

W1HIS: <http://www.yccc.org/Articles/W1HIS/CommonModeChokesW1HIS2006Apr06.pdf>

K9YC: <http://www.audiosystemsgroup.com/RFI-Ham.pdf>

APPENDIX C – Cables and Bridges

Cables and Bridges are an experimental capability – *microHAM* provides no support or warranty for the Cables and Bridges capability. These features are undocumented but relatively self-explanatory.

Cables (cross wired, aka “null modem” cable) create interconnected virtual ports which can be configured as a bus, point to point pair like com0com, or point to multi-point (star, splitter or combiner) - like VSPE. Applications may connect to each other using cables. For example, the Secondary CAT Serial Port in DXLab Suite's Commander may connect to one end of a cable and a software panadapter might connect to the other end of the cable. There is one exception, cables ***can not*** connect to any port used in Router's Ports tab.

The TX check box designates the port as a bidirectional port – the TxD line is active/connected. If the TX box is unchecked, the port is a “receive only” (listen) port like the “listen” leg of the “Y” cable used between a computer serial port and transceiver for devices like a SteppIR controller, “AT-Auto” tuner or some automatic power amplifiers.

Bridges (straight “extender” cable) allow connecting any two (existing) ports - serial port to serial port, serial port to virtual port (cable), or virtual port (cable) to virtual port (cable) but again Bridges ***can not*** connect to any port used in Router's Ports tab.

The only purpose of cables and bridges is to replace third party software serial splitters or software null modem connections like Com0com, DDutil, LP-Bridge, VSPE, etc. that may conflict with the Eltima VSPAX drivers used by *microHAM* USB Device Router. In this regard, *microHAM* USB Device Router provides a means to enable and configure the capabilities that exist in the Eltima VSPAX product.

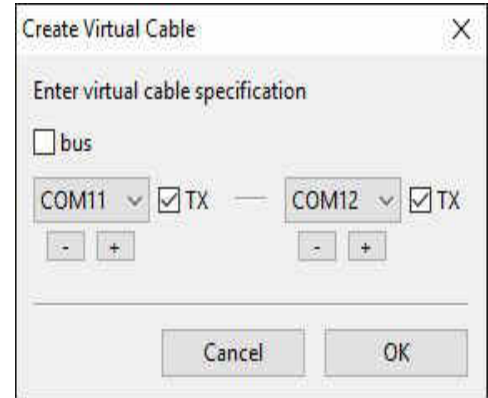

APPENDIX D – Typical Hardware Configurations

Basic micro2R setup

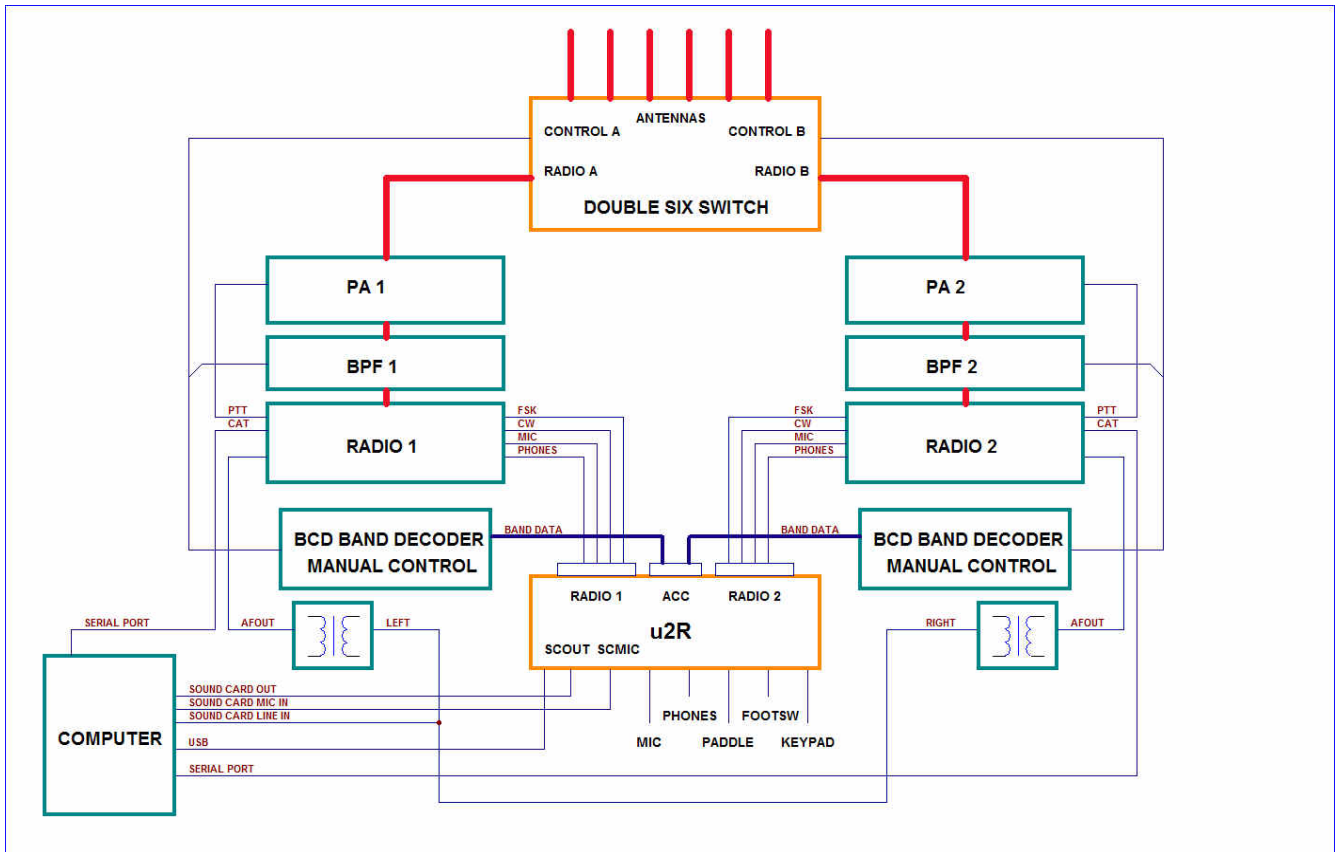

Special notes:

- The CAT port of each radio is connected to the computer serial port or USB to serial port adapters. Use appropriate level converter as necessary
- 3rd party band decoders used for automatic Antenna and BPF switching must use the Yaesu TTL band data format. 3rd party band decoder control is provided by the logging software – it is not automatically determined from the operating frequency.
- For digital mode operation, the constant level audio output from each radio must be isolated using audio transformers. The left radio (Radio 1) should be connected to the left audio channel (tip and sleeve) of the sound card line input. The right radio (Radio 2) should be connected to the right audio channel (ring and sleeve) of the stereo sound card Line input.

micro2R + Station Master setup

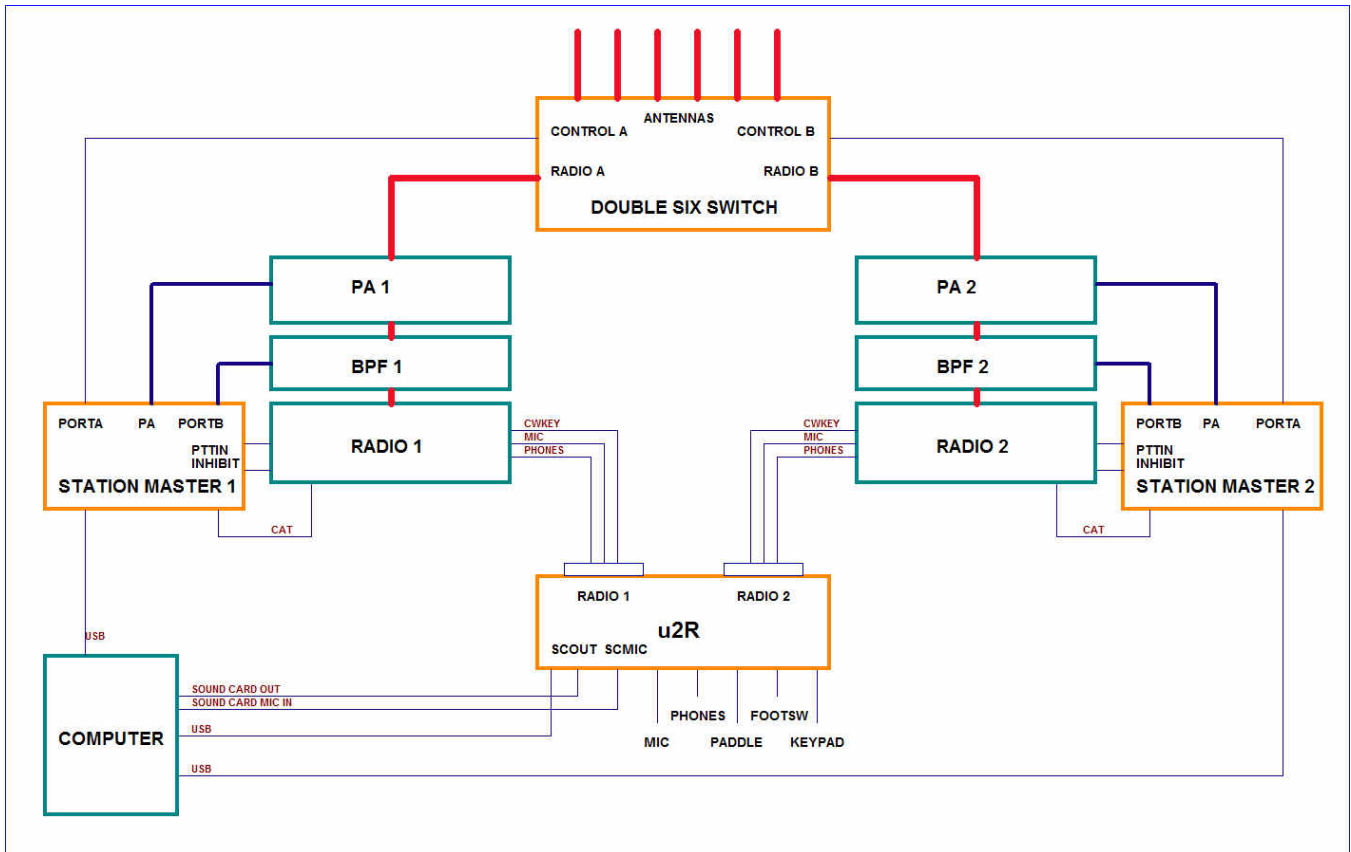

Special notes:

- The CAT port of each radio is connected to its Station Master.
- Station Master provides computer control (CAT), automatic antenna control and BPF switching.
- PTTIN of each Station Master can be connected in parallel with appropriate PTTIN of u2R.

micro2R + micro KEYER II setup

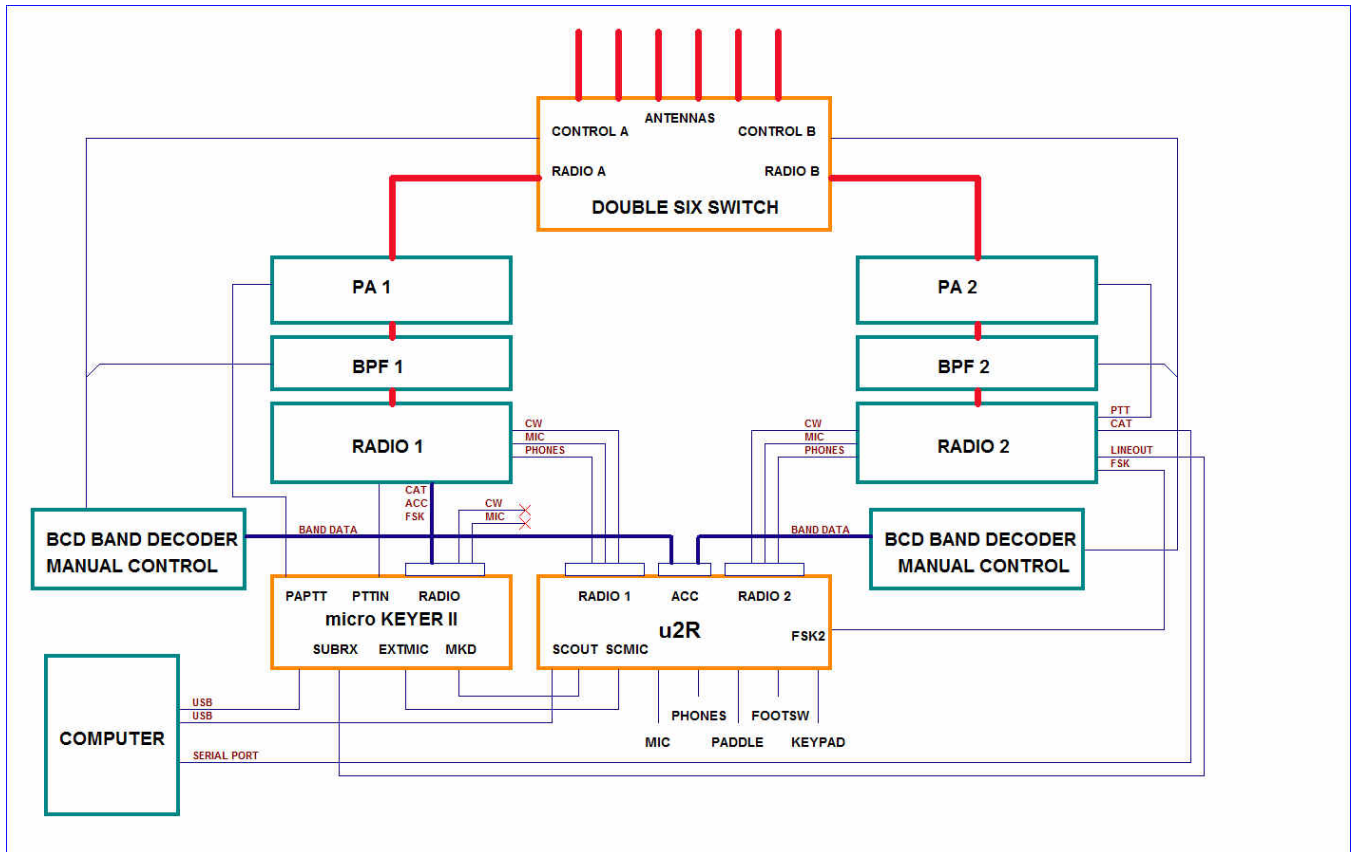

Special notes:

- The CW and microphone outputs from microKEYER II to Radio 1 should be disconnected. The microphone, PTT and CW outputs from u2R should be used instead.
- The station microphone or headset should be connected to u2R.
- The WinKey in MKII is not used. The logging program must use the WinKey port of u2R.
- Use microHAM CODEC as the sound card with u2R.
- Use FSK port on MKII for Radio1 instead of Radio 1 FSK port of u2R.
- Constant level audio output from Radio 2 can be connected to the SUBRX input of MKII instead of 2nd RX of Radio 1. This way logger gets Radio1 audio in left channel and Radio 2 audio in right channel of microHAM codec.
- PTTIN of MKII can be connected in parallel with Radio 1 PTTIN of u2R.
- 3rd party band decoders used for automatic Antenna and BPF switching must use the Yaesu TTL band data format. 3rd party band decoder control is provided by the logging software – it is not automatically determined from the operating frequency.

micro2R + micro KEYER II + Station Master

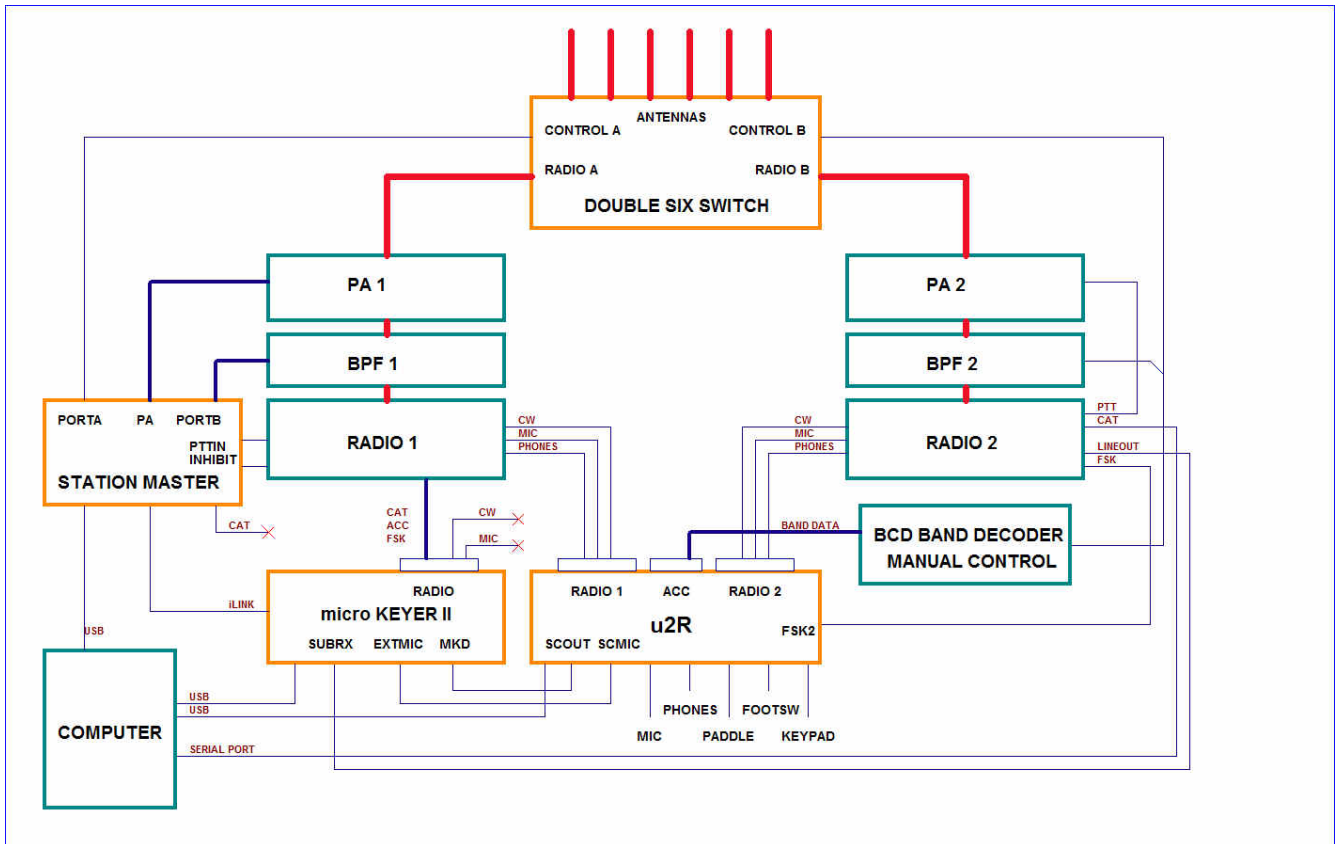

Special notes:

- The CW and microphone outputs from microKEYER II to Radio 1 should be disconnected. The microphone, PTT and CW outputs from u2R should be used instead.
- The station microphone or headset should be connected to u2R.
- The WinKey in MKII is not used. The logging program must use the WinKey port of u2R.
- Use microHAM CODEC as the sound card with u2R.
- Use FSK port on MKII for Radio1 instead of Radio 1 FSK port of u2R.
- Constant level audio output from Radio 2 can be connected to the SUBRX input of MKII instead of 2nd RX of Radio 1. This way logger gets Radio1 audio in left channel and Radio 2 audio in right channel of microHAM codec.
- PTTIN of MKII can be connected in parallel with Radio 1 PTTIN of u2R.
- 3rd party band decoders used for automatic Antenna and BPF switching must use the Yaesu TTL band data format. 3rd party band decoder control is provided by the logging software – it is not automatically determined from the operating frequency.

micro2R + 2 x micro KEYER II + 2 x Station Master

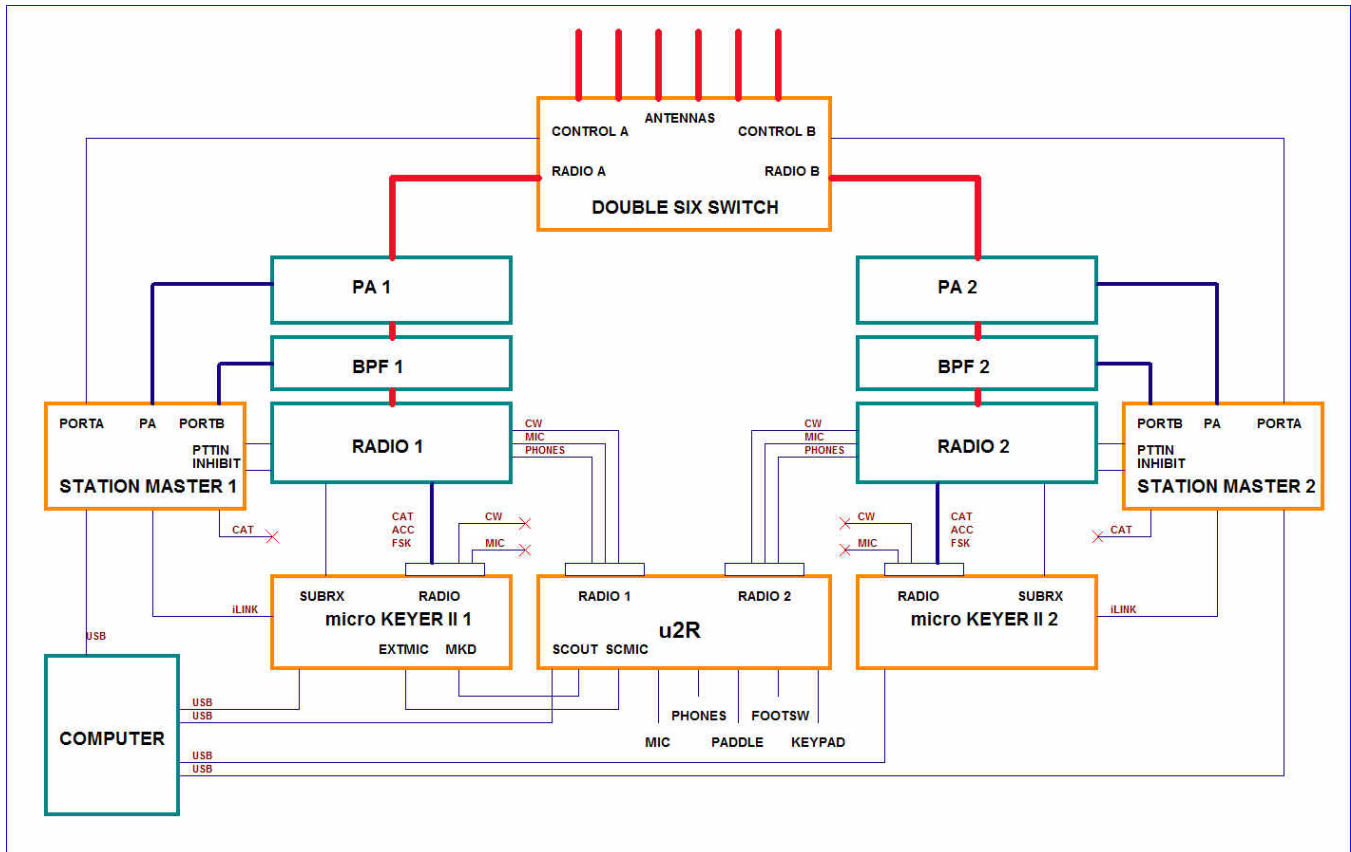

Special notes:

- The CW and microphone outputs from both microKEYER II should be disconnected. The microphone, PTT and CW outputs from u2R should be used instead.
- The station microphone or headset should be connected to u2R.
- The MK II WinKey are not used. The logging program must use the WinKey port of u2R.
- Use microHAM CODEC from the first MK II as the sound card with u2R.
- Use FSK port on MKII for Radio1 instead of the Radio 1 FSK port of u2R.
- Use FSK port on MKII for Radio2 instead of the Radio 2 FSK port of u2R.
- PTTIN of each MKII can be connected in parallel with the appropriate PTTIN of u2R.
- For digital modes use microHAM Codec 1 of MKII 1 for Radio 1 and microHAM Codec 2 of MKII 2 for Radio 2.

micro2R + Single micro KEYER II + 2 x Station Master

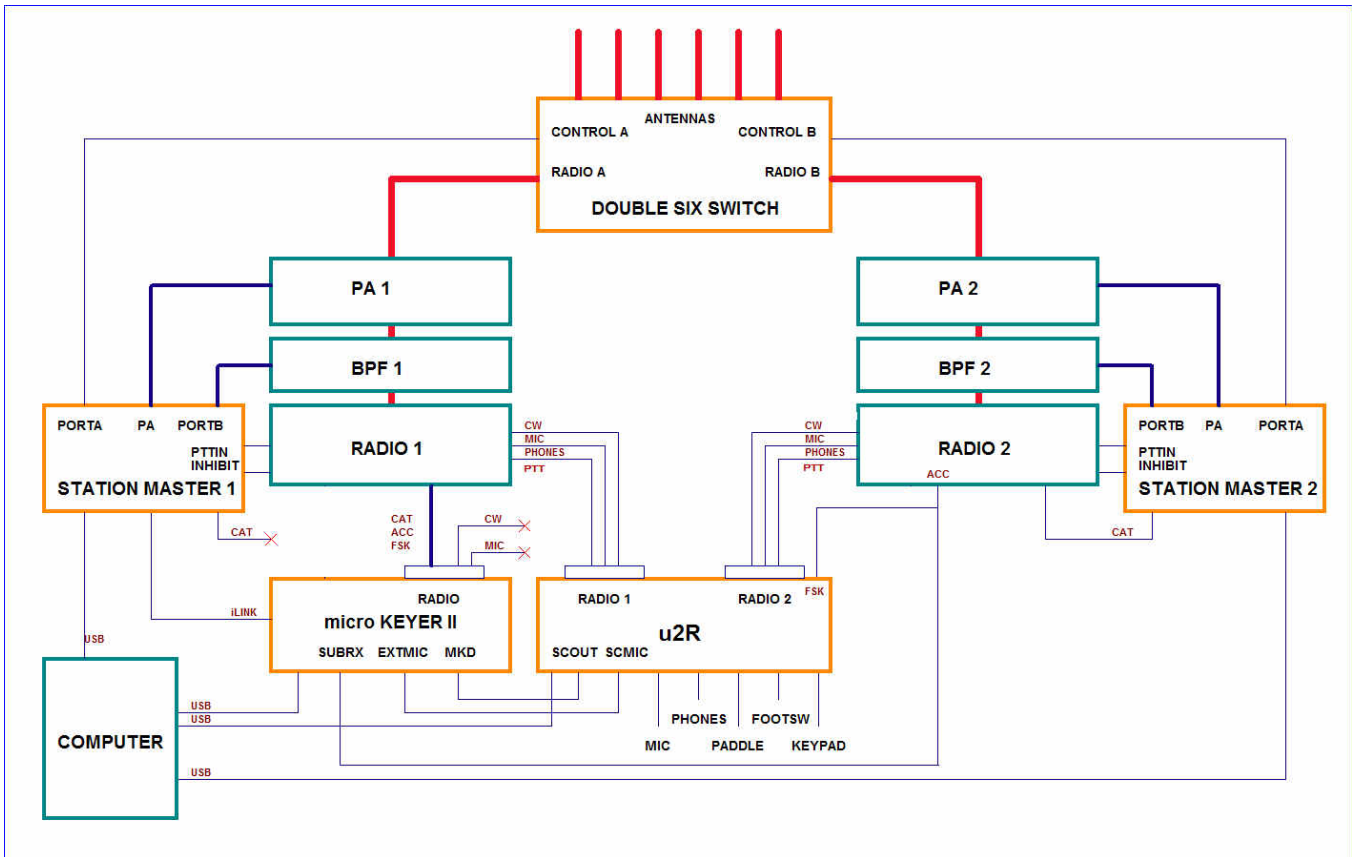

Special notes:

- The CW and microphone outputs from microKEYER II should be disconnected. The microphone, PTT and CW outputs from u2R should be used instead.
- The station microphone or headset should be connected to u2R.
- The MK II WinKey is not used. The logging program must use the WinKey port of u2R.
- Use microHAM CODEC from the MK II as the sound card with u2R.
- Use FSK port on MKII for Radio1 instead of the Radio 1 FSK port of u2R.
- PTTIN of MKII can be connected in parallel with Radio 1 PTTIN of u2R.
- For RTTY use microHAM Codec L for Radio 1 and microHAM Codec R (Sub RX) for Radio 2 in SO2R. If doing SO2V on Radio 1 use L for Main RX and R (Sub RX) for Sub Rx – in this case it will be necessary to use a second sound card to support the second radio for SO2R.

micro2R + 2 x USB Interface III

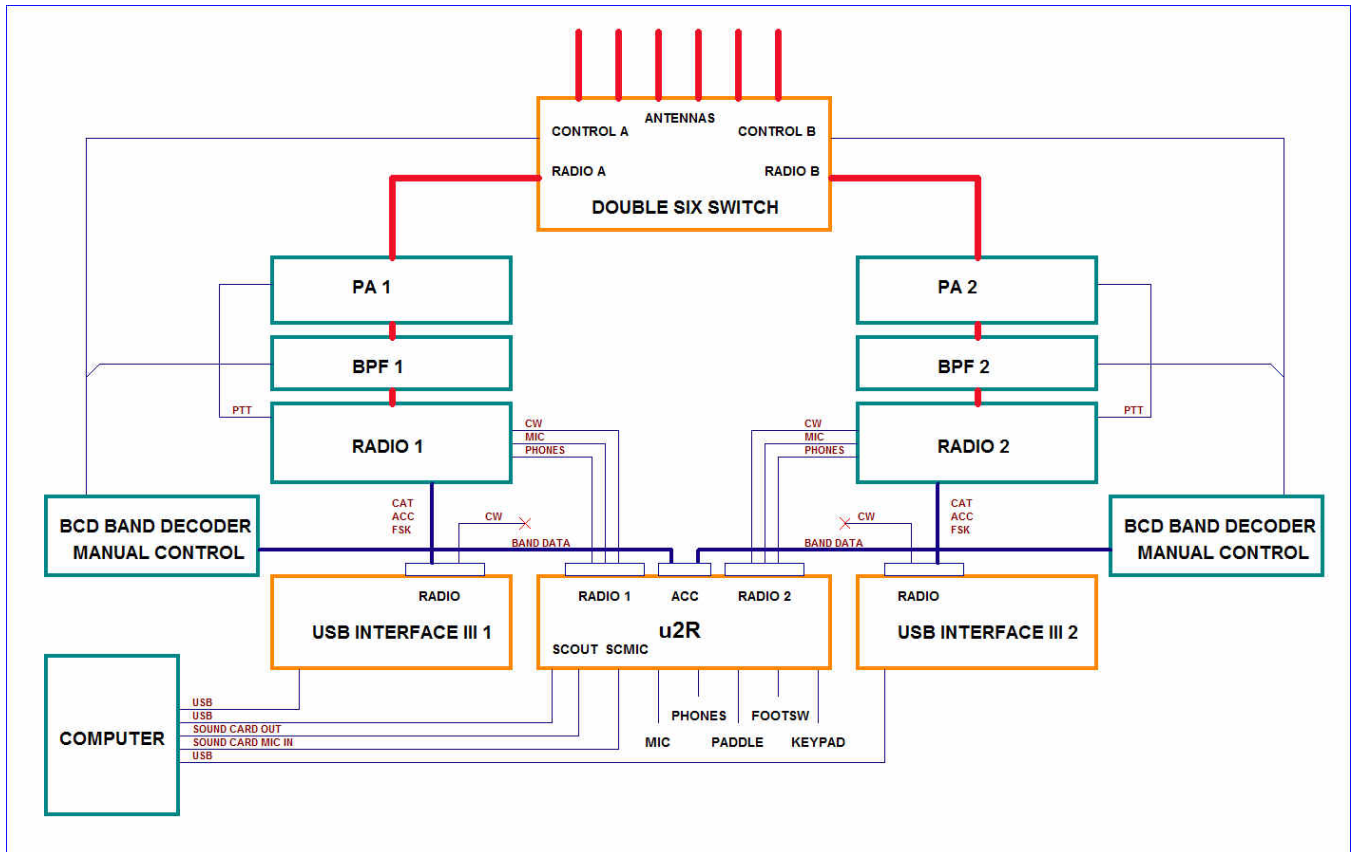

Special notes:

- The CW outputs from the USB Interfaces should be disconnected.
- Use the micro2R CW/WinKey ports for CW.
- A computer sound card must be used for SSB DVK.
- For digital modes use USB Audio Codec 1 of USBIII 1 for Radio 1 and USB Audio Codec 2 of USBIII 2 for Radio 2.
- 3rd party band decoders used for automatic Antenna and BPF switching must use the Yaesu TTL band data format. 3rd party band decoder control is provided by the logging software – it is not automatically determined from the operating frequency.

micro2R + *microKEYER*

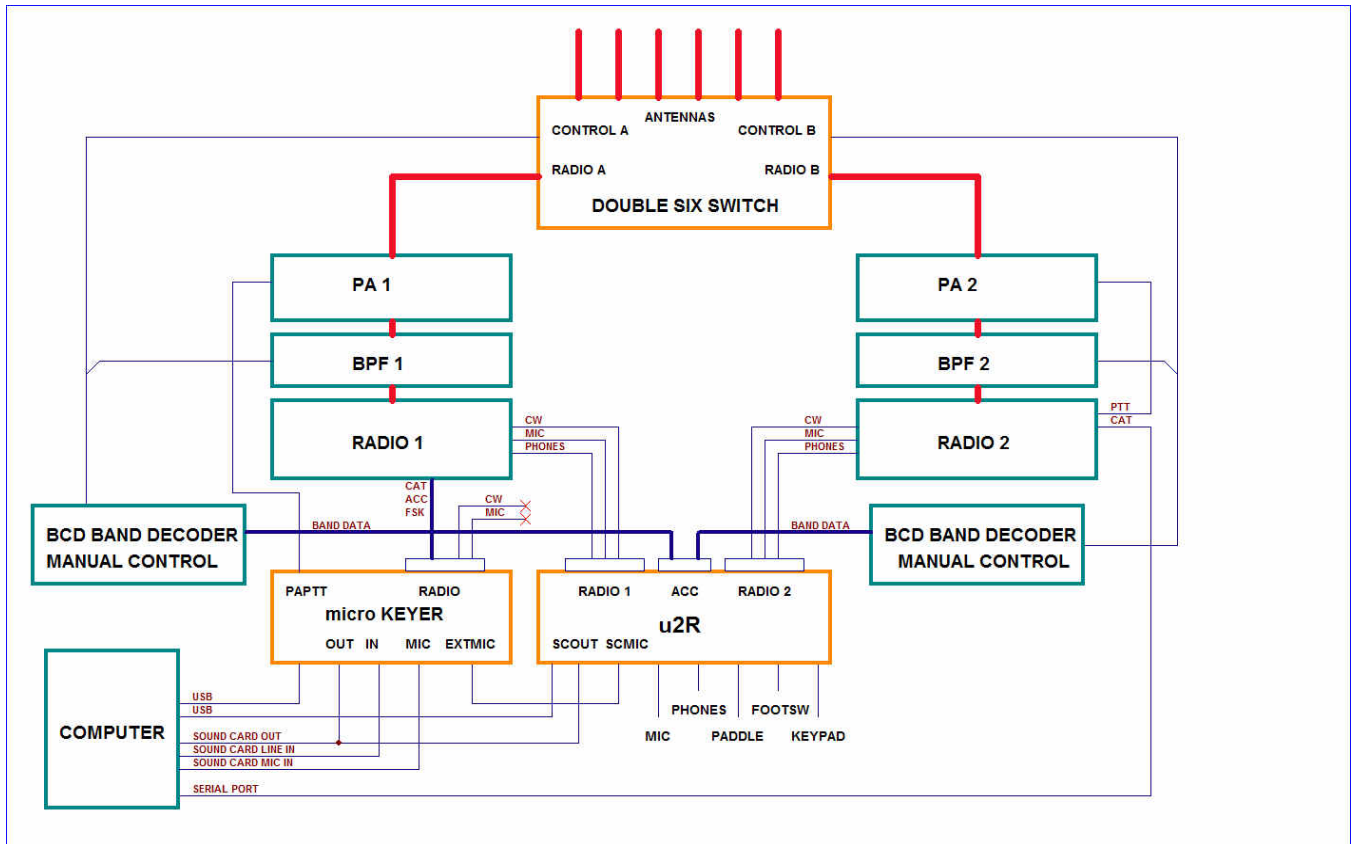

Special notes:

- The CW and microphone outputs from microKEYER should be disconnected. The microphone, PTT and CW outputs from u2R should be used instead.
- The station microphone or headset should be connected to u2R.
- The microKEYER WinKey is not used. The logging program must use the WinKey port of u2R.
- Use FSK port on MK for Radio1 instead of Radio 1 FSK port of u2R.
- For digital mode operation, the constant level audio output from each radio should be isolated using audio transformers. The sound card In line from microKEYER should be connected to the left audio channel (tip and sleeve) of the sound card line input. The right radio (Radio 2) should be connected to the right audio channel (ring and sleeve) of the stereo sound card Line input using an external transformer.
- 3rd party band decoders used for automatic Antenna and BPF switching must use the Yaesu TTL band data format. 3rd party band decoder control is provided by the logging software – it is not automatically determined from the operating frequency.